

**geotech**

# Geocontrol PRO

INSTALLATION AND OPERATION MANUAL



Rev. 1 03/18/04 Part # 11150263

# TABLE OF CONTENTS

Chapter 1: System Description .....	p. 05
Function and Theory.....	p. 05
Chapter 2: System Installation.....	p. 06
Chapter 3: System Operation .....	p. 07
Chapter 4: System Maintenance .....	p. 08
Chapter 5: System Troubleshooting .....	p. 09
Chapter 6: System Specifications.....	p. 10
Chapter 7: System Schematic .....	p. 11
Chapter 8: Replacement Parts List.....	p. 12
Warranty and Repair .....	p. 16

# DOCUMENTATION CONVENTIONS

This manual uses the following conventions to present information:



**WARNING**

An exclamation point icon indicates a **WARNING** of a situation or condition that could lead to personal injury or death. You should not proceed until you read and thoroughly understand the **WARNING** message.



**CAUTION**

A raised hand icon indicates **CAUTION** information that relates to a situation or condition that could lead to equipment malfunction or damage. You should not proceed until you read and thoroughly understand the **CAUTION** message.



**NOTE**

A note icon indicates **NOTE** information. Notes provide additional or supplementary information about an activity or concept.

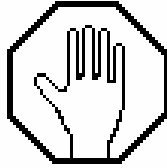

**In order to ensure that your Controller has a long service life and operates properly, adhere to the cautions below and read this manual before use.**

- **Controller power input source must not exceed maximum ratings.**
- **Controller must be wired to a negative ground system.**
- **Controller may not operate properly with excess wiring not supplied by manufacturer.**
- **Avoid spraying fluid directly at controller.**
- **Never submerge controller.**
- **Avoid pulling on wires to unplug controller wiring.**
- **Avoid using controller with obvious physical damage.**
- **To prevent controller damage, avoid dropping controller.**

# GEOCONTROL PRO



Figure 1

# Chapter 1: System Description

## Function and Theory

The Geocontrol Pro is a unique controller for operating down well bladder sampling pumps. When an external 12 VDC power source is connected to the controller, the internal compressor is capable of producing 100 psi. This pressure allows the user to take samples from a depth of 200ft.

The controller offers a variable cycle timer for controlling the portable compressor's on time and off time. While the compressor is on, air is pushed down well to the bladder pump compressing the internal bladder and evacuating the liquid in the pump. When the compressor shuts off, the air pressure in the pump exhausts out of the system, via the fill rate valve, allowing liquids to enter the pump. The fill rate valve allows the user to restrict the air exhaust from around the bladder.



*NOTE: The fill rate valve is important for achieving a desired filling rate of the down well bladder.*

## Chapter 2: System Installation

To operate the Geocontrol Pro, make sure the power switch is in the off position and plug the power input cord into a 12V lighter receptacle on a negatively grounded system. If the controller is to be wired directly to a 12V battery, make sure to connect the positive (red) alligator clip to the positive (red) battery terminal and connect the negative (black) alligator clip to the negative (black) battery terminal. Continue by plugging the pump's air line into the air out port on the controller's face. Plumb the pump's discharge line into a suitable container. Check all wiring and plumbing for correctness.

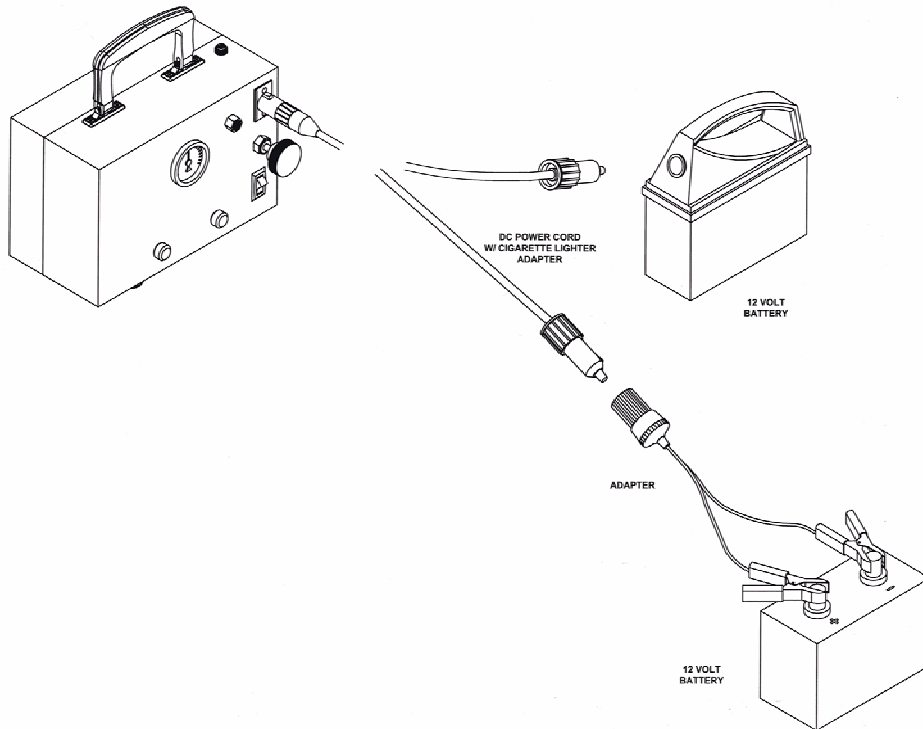

Figure 2 – Installation Diagram

## Chapter 3: System Operation

<b>Discharge Time</b>	The time it takes to squeeze the bladder and push the water out of the pump. The deeper the pump and the larger the bladder volume, the longer the discharge time will have to be.
<b>Fill Time</b>	The time allowed for the bladder to refill. Larger bladder volumes and slower fill rates will require longer fill times.
<b>Fill Rate</b>	The rate at which the bladder pump is allowed to refill under hydrostatic pressure. <b>NOTE: The slower the fill rate, the longer the fill time should be set at.</b>

By setting the controller fill timer to zero, continuous pumping is possible. Although the compressor is rated for continuous use, excess heat will begin to build up. **Never exceed the recommended duty cycles for the Geocontrol Pro.**

Adjust the Geocontrol Pro's "Fill" and "Discharge" timer knobs to the desired cycle times. Adjust the "Fill Rate" knob to somewhere near the middle of the scale. **NOTE: The more constricted the flow rate out of the pump, the longer the fill time will need to be.** Turn the controller power switch on. The pump unit should begin pumping fluid. If the discharge from the pump falls off before the discharge cycle is complete, the fill time is set too low relative to the fill rate or the discharge time is set too high and the pump is empty. This can be supported watching the air line pressure gauge for runaway pressures.

If the discharge cycle ends before the pump is finished discharging, the discharge time can be increased to maximize yield from the pump. Slowly adjust the "Fill Rate" knob to get the desired flow rate into the pump.

**NOTE: The air line pressure gauge can be utilized to maximize efficiency. This gauge will indicate a pressure (during the discharge cycle) that is directly proportionate to the depth to the pump (2.3 feet = 1 psi). When the bladder in the pump is empty of liquids and the Geocontrol Pro is still on the discharge cycle, the pressure will increase much faster. If a quick pressure increase is noticed, turn down the discharge time, once each cycle, until the compressor turns off at the moment of runaway pressure.**

## **Chapter 4: System Maintenance**

Unit must be returned to Geotech for any service.

In order to provide long service life, keep the Geocontrol Pro clean. Clean controller by wiping off with a mild detergent. Apply cleaning solution to a soft cloth and wipe off the controller. Avoid soaking or directly spraying liquids on the Geocontrol Pro.

## **Chapter 5: System Troubleshooting**

The Geocontrol Pro has been designed and manufactured to provide a long service life and trouble free operation in the field.

If the compressor, during charge cycles, becomes sluggish, check supply voltage. If the supply voltage falls below 12 VDC, the compressor's performance will be directly affected. A fully charged battery will produce the best results.

Other sources of low pump output may be the 12V lighter receptacles or plugs. Make certain these connections are fully plugged in. Once fully plugged in, rotating the connection can help if there is a dead spot in the connector. Also, normal wear and tear on cables, receptacles and plugs could cause undesired operations. Check for fatigue, cracks, rust etc.

## Chapter 6: System Specifications

Power usage	90-105 W
Voltage	12-14 VDC
Over current protection	15 Amps
Fill timer range	0-60 seconds
Discharge timer range	0-60 seconds
Maximum pump depth	200 FT
Maximum compressor pressure	100 PSI
Duty cycle	40% on, 60% off
Operational temp	50°F-104°F (10°C-40°C)

### FEATURES

Variable pump fill control.  
Variable pump discharge time control.  
Variable pump fill time control.  
Internal compressor is thermally protected.  
Interchangeable pump connection configurations.



1. For use with negative (-) ground systems only.
2. Exceeding the recommended duty cycle will cause over heating.
3. Damage will result if the supply voltage exceeds 14 VDC.

# Chapter 7: System Schematic

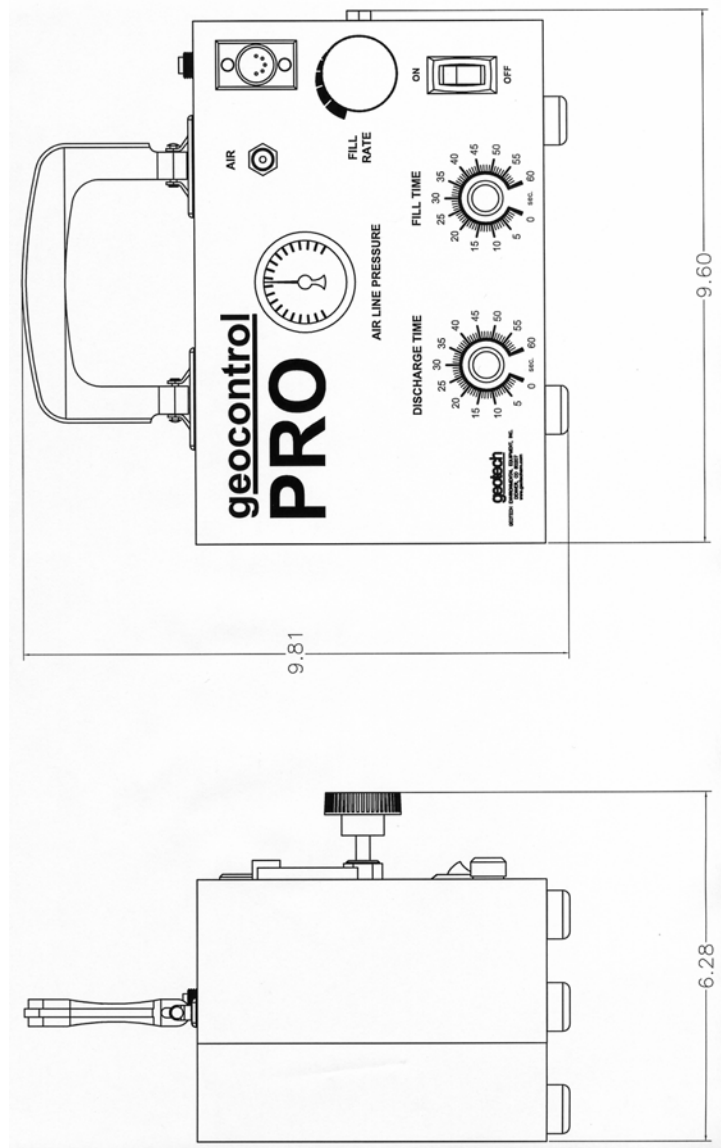

## Chapter 8: Replacement Parts List

Geocontrol Pro	PN	81150012
Cigarette Cable Adapter Set	PN	57500008
12VDC Battery and Charger	PN	77250000
Pressure Gauge	PN	11150254
Cycle Module	PN	51150044
Compressor	PN	11150258
Knob	PN	11150244

## Notes

## Notes

## Notes

## The Warranty

For a period of one (1) year from date of first sale, product is warranted to be free from defects in materials and workmanship. Geotech agrees to repair or replace, at Geotech's option, the portion proving defective, or at our option to refund the purchase price thereof. Geotech will have no warranty obligation if the product is subjected to abnormal operating conditions, accident, abuse, misuse, unauthorized modification, alteration, repair, or replacement of wear parts. User assumes all other risk, if any, including the risk of injury, loss, or damage, direct or consequential, arising out of the use, misuse, or inability to use this product. User agrees to use, maintain and install product in accordance with recommendations and instructions. User is responsible for transportation charges connected to the repair or replacement of product under this warranty.

## Equipment Return Policy

A Return Material Authorization number (RMA #) is required prior to return of any equipment to our facilities, please call 800 number for appropriate location. An RMA # will be issued upon receipt of your request to return equipment, which should include reasons for the return. Your return shipment to us must have this RMA # clearly marked on the outside of the package. Proof of date of purchase is required for processing of all warranty requests.

This policy applies to both equipment sales and repair orders.

FOR A RETURN MATERIAL AUTHORIZATION, PLEASE CALL OUR  
SERVICE DEPARTMENT AT 1-800-833-7958 OR 1-800-275-5325.

Model Number: \_\_\_\_\_

Serial Number: \_\_\_\_\_

Date: \_\_\_\_\_

## Equipment Decontamination

Prior to return, all equipment must be thoroughly cleaned and decontaminated. Please make note on RMA form, the use of equipment, contaminants equipment was exposed to, and decontamination solutions/methods used.

Geotech reserves the right to refuse any equipment not properly decontaminated. Geotech may also choose to decontaminate equipment for a fee, which will be applied to the repair order invoice.

**Geotech Environmental Equipment, Inc**  
8035 East 40<sup>th</sup> Avenue Denver, Colorado 80207  
(303) 320-4764 • **(800) 833-7958** • FAX (303) 322-7242  
email: [sales@geotechenv.com](mailto:sales@geotechenv.com) website: [www.geotechenv.com](http://www.geotechenv.com)