

# SentryRAE

## PGM-5010

MULTI-GAS MONITOR



## Operation & Maintenance Manual

Document Number: 049-4001

Revision A, April 2002



This product may be covered by one or more of the following U.S. Patents:

5,393,979  
6,313,638

5,561,344  
6,333,632

5,773,833  
6,320,388

6,225,633



## **- READ BEFORE OPERATING -**

This manual must be carefully read by **ALL** individuals who have or will have the responsibility for using, maintaining, or servicing this product. The product will perform as designed only if it is used, maintained, and serviced in accordance with the manufacturer's instructions.

When the SentryRAE (PGM-5010) Monitor is removed from the transport case and turned on for the first time, there may be residual organic or inorganic vapor trapped inside the detector chamber. The initial PID or toxic sensor reading may indicate a few ppm. Ensure an area free of organic or toxic vapors and turn the monitor on. After running the monitor for several minutes, the residual vapor in the detector chamber should clear, and the reading should return to zero.

The battery of the SentryRAE Monitor will slowly drain even when it is not on. If the monitor has not been charged for 5-7 days, the battery voltage will be low. Therefore, it is good practice to charge the monitor before each use. It is also recommended to fully charge the monitor for **AT LEAST 10 HOURS** before initial use. See Section 6 for more information on battery charging and replacement.

### **CAUTION!**

<p>To reduce the risk of electric shock, turn the power off before removing the monitor cover. Disconnect the battery before removing sensor module for service. Never operate the monitor when the cover is removed. Remove monitor cover and sensor module only in an area known to be non-hazardous.</p>
---

**The SentryRAE Multi-Gas Monitor (PGM-5010) is intrinsically safe for use in the following areas:**

- **Class I, Division 1, Groups A, B, C, D**
- **Class II, Groups E, F, G**
- **Temp T3C**

# **WARNINGS**

Use only RAE Systems rechargeable battery pack part number 029-3051, or alkaline battery pack part number 029-3052. Use only DURACELL Mn1400 or ENERGIZER E93 C size batteries with alkaline battery pack. This instrument has not been tested in an explosive gas/air atmosphere having an oxygen concentration greater than 21%. Substitution of components may impair intrinsic safety. Recharge batteries only in non-hazardous locations.

**STATIC HAZARD:** Clean only with a damp cloth.

For safety reasons this equipment must be operated and serviced by qualified personnel only. Read and understand instruction manual completely before operating or servicing.

Only the combustible gas detection portion of this instrument has been assessed for performance.

Before each day's usage, sensitivity must be tested on a known concentration of methane gas equivalent to 20-50% of full-scale concentration. Accuracy must be within  $\pm 20\%$  of actual. Accuracy may be corrected by calibration procedure.

Any rapid up-scale reading followed by a declining or erratic reading may indicate a gas concentration beyond upper scale limit which may be hazardous.

The calibration of all newly purchased RAE Systems instruments should be tested by exposing the sensor(s) to known concentration calibration gas before the instrument is used or put into service. For maximum safety, the accuracy of the SentryRAE should be checked by exposing the sensor(s) to known concentration calibration gas before each day's use.

# **AVERTISSEMENT**

Utiliser seulement l'ensemble de batterie RAE Systems, la référence 029-3051 ou 029-3052. Cet instrument n'a pas été essayé dans une atmosphère de gaz/air explosive ayant une concentration d'oxygène plus élevée que 21%. La substitution de composants peut compromettre la sécurité intrinsèque. Ne charger les batteries que dans un emplacement désigné non dangereux.

## **DANGER RISQUE D'ORIGINE ELECTROSTATIQUE:**

Nettoyer uniquement avec un chiffon humide.

Pour des raisons de sécurité, cet équipement doit être utilisé, entretenu et réparé uniquement par un personnel qualifié. Étudier le manuel d'instructions en entier avant d'utiliser, d'entretenir ou de réparer l'équipement.

Uniquement, la portion pour détecter les gaz combustibles de cet instrument a été évaluée.

Avant chaque utilisation journalière vérifier la sensibilité avec une concentration connue de méthane équivalente à 20-50% de la pleine échelle. La précision doit être comprise entre  $\pm 20\%$  de la valeur vraie et peut être corrigée par une procédure de recalibrage.

Toute lecture rapide et positive, suivie d'une baisse subite au erratique de la valeur, peut indiquer une concentration de gaz hors gamme de détection qui peut être dangereuse.

La calibration de toute instruments de RAE Systems doit être testé en exposant l'instrument à une concentration de gaz connue par une procédure de recalibrage avant de mettre en service l'instrument pour la première fois. Pour une sécurité maximale, la sensibilité du SentryRAE doit être vérifié en exposant l'instrument à une concentration de gaz connue par une procédure de recalibrage avant chaque utilisation journalière.



## TABLE OF CONTENTS

---

<b>1. General Information</b>	<b>1-1</b>
1.1 General Specifications	1-2
<b>2. Operation of SentryRAE</b>	<b>2-1</b>
2.1 Physical Description	2-2
2.2 Keys and Displays	2-4
2.3 Turn Power On/Off	2-5
2.4 Data Protection	2-6
2.5 Operations	2-7
2.5.1 Text Mode	2-8
2.5.2 Display Mode	2-9
2.5.3 Program Mode	2-13
2.6 Alarm Signals	2-14
2.7 Back Light	2-16
2.8 Preset Alarm Limits and Calibration	2-17
2.9 Integrated Sampling Pump	2-18
2.10 Datalogging	2-19
<b>3. Operation of Accessories</b>	<b>3-1</b>
3.1 Battery Charging Operation	3-2
3.2 Interchangeable Battery Packs	3-3
3.3 Water Trap Filter	3-5
3.4 Remote Sampling Probe or Teflon Tubing	3-6
3.5 Dilution Fitting	3-7
3.6 Calibration Adapter	3-8
<b>4. Programming SentryRAE</b>	<b>4-1</b>
4.1 Program Mode	4-2
4.2 Keys of Program Mode	4-4
4.3 Entering into Program Mode	4-5
4.4 Calibration of SentryRAE	4-6
4.4.1 Fresh Air Calibration	4-7
4.4.2 Sensor Calibration Time	4-8
4.4.3 Multiple Sensor Calibration	4-9
4.4.4 Single Sensor Calibration	4-12
4.4.5 Modify Span Gas Value	4-14
4.4.6 Change LEL/VOC Span Gas	4-15

## TABLE OF CONTENTS

---

4.5	Change Alarm Limits	4-17
4.6	View or Change Datalog	4-19
4.6.1	Reset Peak and Minimum	4-20
4.6.2	Clear All Data	4-21
4.6.3	Change Datalog Period	4-22
4.6.4	Select Data Type	4-23
4.6.5	View Datalog	4-24
4.6.6	Enable/Disable Datalog	4-25
4.7	Change Monitor Setup	4-26
4.7.1	Change Site ID	4-27
4.7.2	Change User ID	4-28
4.7.3	Change Alarm Mode	4-29
4.7.4	Change User Mode	4-30
4.7.5	Change Real-time Clock	4-31
4.7.6	Change Back Light Mode	4-32
4.7.7	Change Password	4-33
4.7.8	Change Pump Duty Cycle	4-34
4.7.9	Change Pump Speed	4-35
4.7.10	Change Averaging Method	4-36
4.7.11	Change Display Language	4-37
4.7.12	Set Temperature Unit	4-38
4.8	Change Sensor Configuration	4-39
4.8.1	Correction Factors	4-40
4.8.2	Change LEL/VOC Gas Selection	4-41
4.8.3	Enable/Disable Sensor	4-44
4.8.4	Change Dilution Ratio	4-45
4.8.5	Change PID Lamp Type	4-46
4.9	Exit Program Mode	4-47
<b>5.</b>	<b>Theory of Operation</b>	<b>5-1</b>

## TABLE OF CONTENTS

---

<b>6. Maintenance</b>	<b>6-1</b>
6.1 Battery Replacement	6-2
6.2 Sensor Replacement	6-3
6.3 PID Sensor Cleaning / Replacement	6-6
6.4 Taking Care of the Lamp	6-8
6.5 Sampling Pump Replacement	6-10
<b>7. Troubleshooting</b>	<b>7-1</b>
7.1 Diagnostic Mode	7-2
7.2 Possible Problems and Solutions	7-8
<b>Appendix A. Navigation Guide</b>	<b>A-1</b>
Normal Mode: Display Menu	A-2
Diagnostic Mode: Display Menu	A-3
Program Mode: Calibration Menu	A-4
Program Mode: Alarm Limit Menu	A-5
Program Mode: Datalog Menu	A-6
Program Mode: Monitor Setup Menu	A-7
Program Mode: Sensor Configuration Menu	A-8
<b>Appendix B. Correction Factors</b>	<b>B-1</b>

### **Acronyms used throughout manual:**

<b>LCD</b>	- Liquid Crystal Display
<b>LED</b>	- Light Emitting Diode
<b>LEL</b>	- Lower Explosive Limit
<b>PC</b>	- Personal Computer
<b>PID</b>	- Photo-Ionization Detector
<b>ppm</b>	- Parts Per Million
<b>RF</b>	- Radio Frequency
<b>STEL</b>	- Short Term Exposure Limit
<b>TWA</b>	- Time Weighted Average
<b>VOC</b>	- Volatile Organic Compound



## INDEX OF TABLES AND FIGURES

---

<b>Table #</b>	<b>Title</b>	<b>Page</b>
1.1	Range, Resolution & Response Time	1-4
2.1	Key Functions During Normal Operation	2-4
2.2	Alarm Signal Summary	2-15
2.3	Alarm Limits and Calibration	2-17
4.1	Programming Keys	4-4
7.1	Critical Parameters	7-2

<b>Figure #</b>	<b>Title</b>	<b>Page</b>
2-1	Front View – Main Components	2-2
2-2	Back View – Main Components	2-3
2-3	Display and Keypad	2-4
3-1	Interchangeable Battery Packs	3-3
5-1	Block Diagram	5-1
6-1	Main Components (Exploded View)	6-1
6-2	Sensor Compartment	6-4
6-3	Detailed Sensor Assembly	6-5



# 1. General Information

The SentryRAE Multi-Gas Monitor is a portable, instrument that provides real-time measurements and activates alarm signals when exposure exceeds preset limits. The programmable monitor contains up to five sensors that will monitor toxic gases, oxygen and combustible gases for workers in hazardous environments. Depending on the type of sensor installed, the SentryRAE is capable of monitoring:

- **Volatile Organic Compounds**  
PID Sensor using 10.6 eV or 11.7 eV UV lamp
- **Inorganic Compounds**  
Substance Specific Electrochemical Sensor(s)
- **Combustible Gases**  
0-100 LEL range with a catalytic bead sensor
- **Oxygen Concentrations**  
Electrochemical Sensor

The SentryRAE (PGM-5010) consists of:

- SentryRAE monitor
- Up to five sensors
- Carbon filters, for monitors equipped with a CO sensor
- Calibration adapter
- Quick Reference Guide
- Operation and Maintenance manual
- Shoulder strap
- Rechargeable Lithium-Ion battery pack
- Charger
- Spare alkaline battery pack
- Ten spare water and dust trap filters
- Three-inch inlet probe
- Hard transport case with pre-cut foam
- Fifteen feet (5 meters) of Teflon<sup>®</sup> tubing
- Tool kit
- Lamp cleaning kit, for monitors equipped with a PID sensor

## 1.1 General Specifications

**Table 1.1 Multi-Gas Monitor Specification**

<b>Dimensions</b>	9.25" L x 5.0" W x 9.25" H (23.5cm L x 12.7cm x 23.5cm)
<b>Weight</b>	8.9 lbs (4.03 kg) with battery
<b>Detector</b>	Up to five sensors: <ul style="list-style-type: none"><li>• PID sensor</li><li>• LEL sensor</li><li>• Electrochemical sensors (3)</li></ul>
<b>Battery</b>	Rechargeable, 7.4V/4.5 Ah, Lithium-Ion battery pack with built-in charger (less than 10 hours charge time)  Six C-cell alkaline battery pack
<b>Operating Time</b>	Up to 36 hours of continuous operation
<b>Display</b>	Two-line, 16-character LCD with manual LED backlight
<b>Keypad</b>	<ul style="list-style-type: none"><li>• [MODE] – operation &amp; programming</li><li>• [Y/+] – operation &amp; programming key</li><li>• [N/-] – operation &amp; programming key</li><li>• [RADIO] – not used</li><li>• [VOICE] – not used</li><li>• [UP/DOWN] – not used</li></ul>
<b>Direct Readout</b>	<ul style="list-style-type: none"><li>• Up to five instantaneous values</li><li>• Sensor name</li><li>• High and low alarm limits for all sensors</li><li>• TWA &amp; STEL values for toxic &amp; VOCs</li><li>• Battery voltage</li><li>• Elapsed time</li></ul>
<b>Alarm Settings</b>	Separate alarm limit settings for TWA, STEL, Low and High alarm
<b>Visible Alarm</b>	100 dB buzzer at 10 cm (typical)

## GENERAL INFORMATION

---

<b>Audible Alarm</b>	Flashing red LED cluster to indicate exceeded preset limits, low battery, or sensor failure
<b>Calibration</b>	Two point field calibration for fresh air and standard reference gas
<b>Attachments</b>	Shoulder strap, optional tripod/wall mounting bracket
<b>Sampling Pump</b>	Internal integrated diaphragm pump with programmable “High” (400 cc) and “Low” (300 cc) flow rate settings
<b>Protection</b>	Password protected calibration settings, alarm limits, and data
<b>Intrinsic Safety</b>	UL Classified for use in: Class I, Division 1, Groups A, B, C, D Class II, Groups E, F, G Temp Code T3C
<b>EM Immunity</b>	No effect when exposed to 0.43 mW/cm <sup>2</sup> RF interference (5 watt transmitter at 12 inches)
<b>Data Storage</b>	20,000 readings (64 hours, 5 channels at 1-minute intervals) in non-volatile memory
<b>Datalog Interval</b>	Programmable 1-3600 seconds
<b>External Alarm</b>	Optional plug in pen size vibration alarm or earphone
<b>Communication</b>	Upload data to PC and download monitor setup from PC through RS-232 link to serial port on PC
<b>Temperature</b>	-20°C to 45°C (-4°F to 113°F)
<b>Humidity</b>	0 % to 95% relative humidity (Non-condensing)
<b>Configuration</b>	2, 3, 4 and 5 gas with pump, equipped with or without datalogging

---

GENERAL INFORMATION

---

<b>CO</b>	0-500 ppm	1 ppm	40 sec
<b>H<sub>2</sub>S</b>	0-100 ppm	1 ppm	35 sec
<b>SO<sub>2</sub></b>	0-20 ppm	0.1 ppm	35 sec
<b>NO</b>	0-250 ppm	1 ppm	30 sec
<b>NO<sub>2</sub></b>	0-20 ppm	0.1 ppm	25 sec
<b>Cl<sub>2</sub></b>	0-10 ppm	0.1 ppm	60 sec
<b>O<sub>2</sub></b>	0-30 %	0.1 %	15 sec
<b>VOC</b>	0-200 ppm	0.1 ppm	10 sec
<b>VOC</b>	200-2000 ppm	1 ppm	10 sec
<b>LEL</b>	0-100 %	1 %	15 sec
<b>HCN</b>	0-100 ppm	1 ppm	200 sec
<b>NH<sub>3</sub></b>	0-50 ppm	1 ppm	150 sec
<b>PH<sub>3</sub></b>	0-5 ppm	0.1 ppm	60 sec

## **2. Operation of SentryRAE**

The SentryRAE Multi-Gas Monitor is a compact, portable instrument that provides real-time measurements and activates alarm signals when exposure exceeds preset limits. Prior to factory shipment, the SentryRAE is preset with default alarm limits, and sensors are pre-calibrated with standard calibration gas. However, the user should calibrate the instrument before first use. After the monitor is fully charged and calibrated, it is ready for immediate operation.

## 2.1 Physical Description

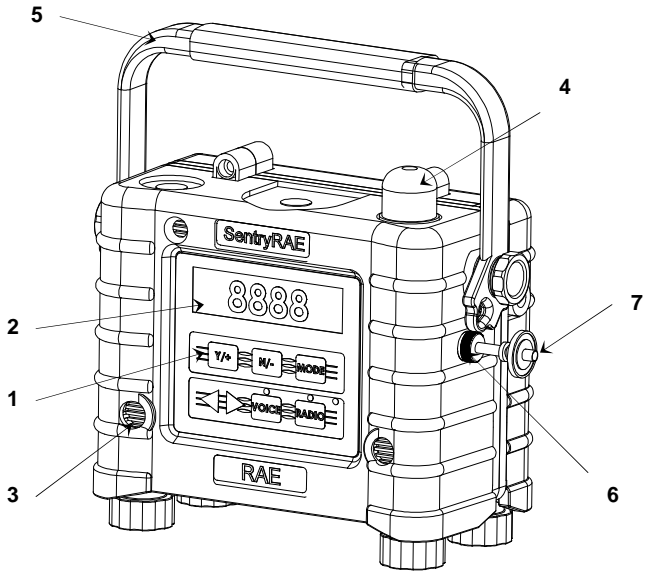

**Figure 2-1** Front View - Main Components of SentryRAE

1. Keypad

[MODE] – operation key & programming key

[Y/+] – operation & programming key

[N/-] – operation & programming key

[RADIO] – not used

[VOICE] – not used

[UP/DOWN] – not used

2. LCD Display with Backlight

3. Audible Alarm Port

4. Red LED Alarm Light

5. Handle

6. Gas Entry Port

7. Water / Dust Filter

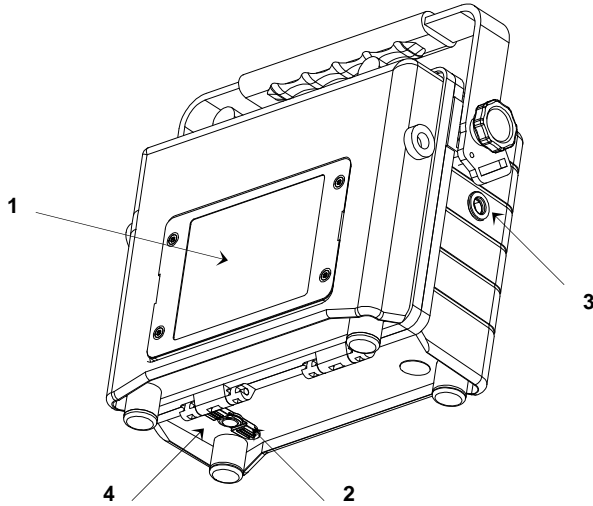

**Figure 2-2** Back View - Main Components of SentryRAE

1. Battery pack - SentryRAE monitors are equipped with interchangeable rechargeable Lithium-Ion and alkaline battery packs
2. Charger port – power jack connects SentryRAE to external DC for charging
3. Gas exit port
4. Serial communication port for PC interface

## 2.2 Keys and Display

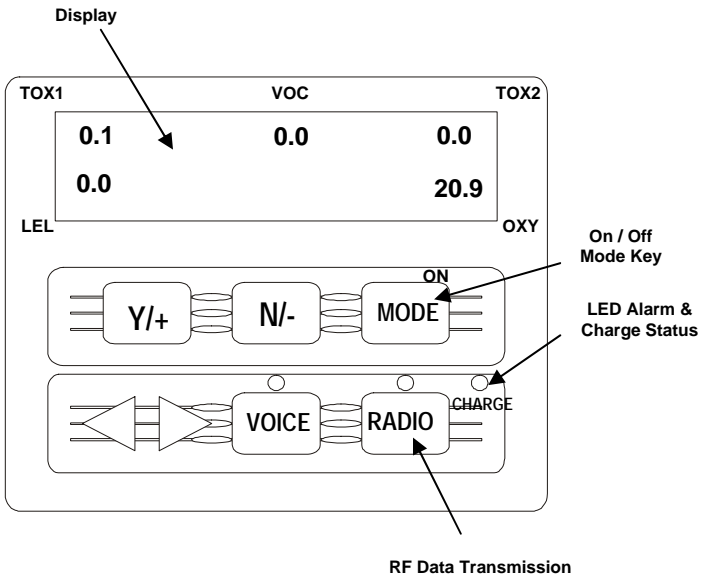

Figure 2-3 SentryRAE Display and Keypad

Table 2.1 Key Functions During Normal Operation	
Key	Function
[MODE]	Turn power on/off Choose different display mode
[N/-]	Toggle backlight on/off Answer "No" Decrease values
[Y/+]	Alarm test and alarm acknowledgment Turn latched alarm off Turn pump or LEL sensor on Answer "Yes" Increase values

## 2.3 Turn Power On/Off

### To turn ON

Press [MODE]. The audio buzzer will beep once, and the screen will display the following, in order:

- “ON!”
- “Multi-gas Monitor Version n.nn” (the software version)
- Custom power-on-name, which can be changed by the customer using the ProRAE Suite Software
- Model number, serial number, current date & time, and temperature
- Each sensor socket to check if a valid sensor is installed  
If a new sensor is installed, a message to remind the user to calibrate the sensor will be displayed followed by a message that the alarm limits have been reset to the default values for the new sensor. If a sensor reaches its expected end of life, a “Warranty Expired” message will be displayed.
- Preset alarm limits for each sensor
- Last calibration date
- Battery voltage
- Shut off voltage
- User mode
- Alarm mode
- Available data storage memory (in hours)
- Datalog mode
- Datalog period (60 seconds)
- Instantaneous reading of the gas concentration in ppm

### To turn OFF

Press and hold [MODE] for 5 seconds. The monitor will beep once every second during the power-down sequence. A countdown timer will show the remaining seconds. After that, the screen will flash “Off!” and then go blank, indicating the monitor is off.

## 2.4 Data Protection

When the monitor is turned off, all the current real-time data including TWA, STEL, Peak and elapsed time are erased. However, the datalog data is preserved in non-volatile memory. Even if the battery is disconnected, the datalog data will not be lost. When the monitor is off, the real-time clock will continue to operate until the battery is completely drained (usually in 5-7 days without any charging).

If the battery is completely drained or is disconnected from the monitor for more than 30 minutes, the real-time clock will be lost. In this case, the user needs to enter the real-time clock information again, as described in Section 4.7.5.

### **Datalog monitor versus Non-Datalog monitor**

There are two versions of the PGM-5010 Multi-Gas Monitors: Datalog monitors and Non-Datalog monitors. A Datalog monitor allows the user to store the gas concentration readings. (See Section 2.10 Datalogging Operations)

During the power on sequence, a letter “D” following the version number indicates that the monitor is configured as a Datalog monitor. The absence of a letter “D” indicates a Non-Datalog monitor.

The user may upgrade a Non-Datalog monitor to a Datalog monitor. Call the factory for information on how to order the upgrade kit.

## 2.5 Operations

The SentryRAE offers three different modes of operation:

- **Text Mode**
- **Display Mode**
- **Program Mode**

### **Time Out Intervals**

A time out interval occurs when nothing is pressed after a minute. The LCD will automatically return to the sensor name, if user is in Text Mode, or the instantaneous reading, if user is in Display or Program Mode.

## 2.5.1 Text Mode

The monitor will display the sensor name after the monitor is turned on. The user can press [MODE] to see the Instantaneous Gas Concentration reading, Battery Voltage or may enter the PC Communication menu. The user may enter Calibration Mode from Text Mode to perform calibrations, but may not change the parameters.

### Displays

The four displays are arranged in a round robin sequence:

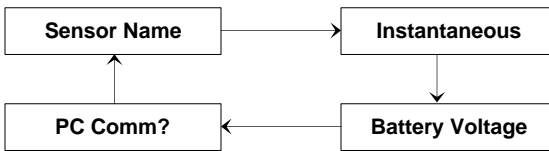

## 2.5.2 Display Mode

The Display Mode includes all the information from Text Mode in addition to the options listed below. The user does not have access to Calibration Mode from the Display Mode; therefore the user may not calibrate or change any parameters. To access each display, press [MODE] once.

1. The **instantaneous reading** is the actual gas concentration in parts per million (ppm) for toxic or VOC gases, percent of volume for oxygen, and percent LEL for combustible gases. Readings are updated in every second.

TOX1	VOC	TOX2
0	0.0	0
0		20.9
LEL		OXY

2. The **sensor names** display:  
 CO, H2S, etc. - up to two toxic sensors  
 VOC - PID sensor  
 LEL - combustible gas sensor  
 OXY - oxygen sensor

TOX1	VOC	TOX2
CO	VOC	H2S
LEL		OXY
LEL		OXY

3. The **peak reading** is the highest reading of each gas concentration since the monitor was turned on. Readings are updated every second with a "Peak" message:

TOX1	VOC	TOX2
5	2.0	3
10	Peak	20.9
LEL		OXY

---

## OPERATION OF SENTRYRAE

4. The **minimum reading** is the lowest reading of each gas concentration since the monitor was turned on. Readings are updated every second with a “Min” message:

TOX1	VOC	TOX2
0	0.0	0
0	Min	19.9

LEL OXY

5. The **STEL reading** only applies to VOC and toxic gases. It is the last fifteen-minute average gas concentration reading, which is updated in every minute and is indicated by a “STEL” message:

Note: “\*\*\*\*” is displayed in the first fifteen minutes.

TOX1	VOC	TOX2
****	****	****
STEL		

LEL OXY

6. The **TWA reading** only applies to VOC and toxic gases. The reading is the accumulated reading of the gas concentration divided by 8 hours since the monitor was turned on. The reading is updated in every minute is indicated by the “TWA” message:

TOX1	VOC	TOX2
0	0.0	0
TWA		

LEL OXY

## OPERATION OF SENTRYRAE

7. The **battery voltage** is the current battery voltage (V) reading. The reading is updated every second and is shown with the shut off voltage:

TOX1	VOC	TOX2
Battery = 7.7 V		
Shut Off at 6.4 V		
LEL		OXY

**Note:** A fully charged battery pack should show 7.7 volts or higher. When the battery voltage falls below 6.6 volts, a flashing “Bat” will appear as a warning message. This means, there will be approximately 20-30 minutes of operating time remaining before the monitor automatically turns off as the battery voltage falls below 6.4 V.

8. The **run time reading** is the accumulated time in hours and minutes the monitor has been on. The reading is updated in every minute and is displayed with the current date, time and temperature:

TOX1	VOC	TOX2
Mar 11, '02		8:30
On = 3:50		20°C
LEL		OXY

9. The **datalog menu** shows the current datalog mode. If the manual datalog mode is selected, the menu will prompt the user to turn datalogging on or off. When “Start Datalog?” displays, press [Y/+] to turn datalogging on. Likewise, when “Stop Datalog?” displays, press [Y/+] to turn it off.
10. The monitor will display the selected **LEL** and **VOC gas name** if the combustible sensor and PID sensor are installed. When an LEL or VOC gas is selected, the display will feature the calculated gas concentration based on the built-in correction factor for the specified gas.
11. “**Print Reading?**” allows the user to print out the gas concentration readings. Connect a serial printer to the monitor. Then press [Y/+] to print.

12. “**Communicate with PC?**” allows the user to upload data from the SentryRAE to their PC or download configuration information from a PC to the SentryRAE. Press [Y/+] and the message “Monitor will pause, OK?” reminds The user that during PC communication there is no real-time monitoring.

Press [Y/+] to proceed and the monitor enters communication standby mode\*. The “Ready...” display will appear. Connect the monitor to the serial port on a PC. The monitor is ready to receive any command from the PC.

Press [MODE] again to return to the first display.

<p><b>*Note:</b> When the monitor is in communication standby mode, it stops monitoring the gas concentration and stops datalogging. Datalogging must be manually restarted when exiting communication standby mode, unless it is in automatic datalogging mode.</p>
--

### 2.4.3 Program Mode

The Program Mode is SentryRAE's default setting. The user may perform all Display Mode functions, in addition to accessing Calibration Mode to perform calibrations or change any parameters.

#### Displays

The twelve functions are arranged in a round robin sequence:

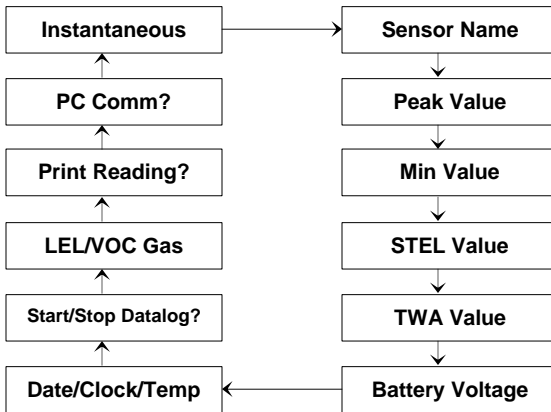

## 2.6 Alarm Signals

The built-in microprocessor continually updates and monitors gas concentration levels. It also compares the readings with programmed TWA, STEL, and Low & High instantaneous gas concentration alarm limit settings. Whenever the concentration exceeds any of the preset limits, the buzzer and red LED will immediately warn the user the alarm condition. Additionally, the SentryRAE will alarm if one of the following conditions occur:

- Battery voltage falls below a pre-set voltage level (6.6V)
- Failure of 10.6 eV or 11.7 eV UV lamp
- LEL sensor is off
- Pump stalls
- Datalog memory is full.

When the low battery alarm occurs, there will be approximately 20-30 minutes of operating time remaining before the monitor automatically turns off as the battery voltage falls below 6.4 V.

### Alarm Signal Disabled

It is extremely important to note that the alarm signals are disabled during the following conditions:

- PC communication standby mode
- Calibration mode.

During these modes of operation, real-time monitoring gas concentration stops. None of the gas concentrations will be calculated, including Peak, STEL and TWA values.

### Alarm Signal Latching

It is possible to setup the SentryRAE from a PC or while user is in Program Mode so that when an alarm condition occurs, the alarm signals remain on even after the alarm condition is no longer present. This is called the "latching alarm" mode. The alternative mode is to automatically reset the alarm signal once the alarm condition is clear. The default alarm mode is automatically reset (See Section 4.7.3 Change Alarm Mode)

<b>Table 2.2 Alarm Signal Summary</b>		
<b>Condition</b>	<b>Alarm Signal</b>	<b>Message on LCD Screen</b>
Gas exceeds "High Alarm" limit	3 beeps & flashes per second	Sensor Name
Gas exceeds "Low Alarm" limit	2 beeps & flashes per second	Sensor Name
Gas exceeds STEL	Beep & flash per second	Sensor Name
Gas exceeds TWA	1 beep & flash per second	Sensor Name
Negative Drift or Over Range	3 beeps & flashes per second	"NEG" or "OVR"
Pump failure	3 beeps & flash per second	"Pump"
LEL sensor off	3 beeps & flash per second	LEL Sensor name and "Off"
PID lamp failure	3 beeps/flash per second	"Lamp"
Low battery	1 flash per second, 1 beep per minute	"Bat"
Memory full	1 flash per second	"Mem"

### **Alarm Signal Testing**

Under normal conditions, it is possible to test the SentryRAE LED, buzzer, and back light by momentarily pressing [Y/+]. The buzzer will beep once, and the LED and backlight will flash once to indicate alarm signals are functioning correctly.



Because alarm signals are disabled during PC Communication and Calibration modes, it is highly recommended to use these modes only in areas known to be non-hazardous, in order to reduce the risk of exposure to hazardous atmospheres.

## 2.7 Backlight

The LCD is equipped with a backlight to assist reading under poor lighting conditions. When the monitor is in Normal Operation mode, the backlight may be manually turned on by pressing and holding [N/-] for one second. Press [N/-] a second time to turn off. If [N/-] is not pressed, the back light will automatically turn off to save power. The back light will automatically activate during alarm condition(s).

**Note:** The LED back light consumes a higher amount of energy from the battery and shortens the operating time of the monitor by 20 - 30%.

## 2.8 Alarm Limits & Calibration

SentryRAE is factory calibrated with standard calibration gas, and is programmed with default alarm limits as listed below. (See Section 4.4 Calibration of SentryRAE and Section 4.5 Change Alarm Limits)

<b>Table 2.3 Alarm Limits &amp; Calibration</b>						
<b>Gas ppm</b>	<b>Cal Gas/ Balance</b>	<b>Unit</b>	<b>TWA</b>	<b>STEL</b>	<b>Low</b>	<b>High</b>
CO	50 / Air	ppm	35	100	35	200
H2S	25 / N2	ppm	10	15	10	20
SO2	5 / N2	ppm	2	5	2	10
NO	25 / N2	ppm	25	25	25	50
NO2	5 / Air	ppm	1	1	1	10
CL2	10 / N2	ppm	0.5	1	0.5	5
O2	20.9 / N2	%	-	-	19.5	23.5
CH4	50 / Air	%LEL	-	-	10	20
HCN	10 / N2	ppm	4.7	4.7	4.7	50
NH3	50 / N2	ppm	25	35	25	50
PH3	5 / N2	ppm	0.3	1	1	2
VOC*	100 / Air	ppm	10.0	25.0	50.0	100.
<b>*100 ppm isobutylene gas is used for VOC gas calibration.</b>						

## 2.9 Integrated Sampling Pump

The SentryRAE Multi-Gas Monitor includes an internal integrated sampling pump with programmable high (400cc) and low (300cc) flow rate settings.

A low pump speed of ~300cc per minute is the factory default setting. This rate increases battery life by about 5%, which results in an increased LEL sensor lifetime (See Section 4.7.9 Change Pump Speed).

The high pump speed setting is required for vapors that are especially reactive or easily absorbed by instrument surfaces. Such vapors include, but are not limited to: Cl<sub>2</sub>, PH<sub>3</sub>, NH<sub>3</sub>, HCN, and semi-volatile organic compounds like diesel fuel and jet fuels. Here are some suggestions for monitoring such compounds:

- Remove the water trap filter for normal calibration and operation, which increases the pump speed to ~300 cc per minute.
- Use inert connecting or sampling tubing, such as Teflon<sup>®</sup> instead of Tygon; make tube connections as short as possible.

The pump automatically turns on when the monitor is turned on; it remains on during normal operation.

If liquid or other substance is sucked into the water filter through the gas entry port and causes the pump to stall, the electronics of the monitor will immediately detect the obstruction and shut down the pump. The alarm will activate, and user will see the flashing "Pump" error message. After the filter is changed or obstacles are removed, press [Y/+] to restart the pump.

## 2.10 Datalogging

The SentryRAE Multi-Gas Monitor calculates and stores gas readings based on the user-specified datalogging period and type of measurement. Two types of gas measurements, average or peak concentration may be stored for each sensor for any datalogging interval. Datalogging intervals may be programmed from one second to sixty minutes in one-second increments. In addition, time stamp, user ID, site ID, serial number, last calibration date, and alarm limits are also stored. Since all data is retained in non-volatile memory, The user may download information to their PC at a later time.

### Datalog Options

Most of the datalogging options may be programmed from the monitor. When the monitor is connected to a PC, additional options may be programmed and then downloaded to the monitor. There are four options to select from:

1. Automatic: automatically starts and stops datalogging when the monitor is turned on and off, respectively.
2. Manual: user manually starts and stops datalogging. User may also set the timer for datalog run times.
3. Periodic: datalogging is scheduled on a daily basis with a preset parameter in hours and minutes.
4. Schedule: datalogging is scheduled for a preset date (month/day) and time (hour/minute).

### Start/Stop Datalogging Manually

1. Press [MODE] to toggle through the normal operation menu until "Start Datalog?" appears.
2. Press [Y/+] to start datalogging.
3. Press [Y/+] again, and "Stop Datalog?" will appear.
4. Press [Y/+] a third time to stop datalogging.

Other Datalog options will automatically start and stop:

### **Datalogging Event**

Each time a datalogging operation is initiated, a datalog event is created. Information, such as start time, datalogging period, alarm limits, etc. will be recorded in the event header, followed by the measurement data. If there are more than 900 measurement intervals recorded in one event, a new event will automatically be created.

### **Datalogging Pause**

Datalogging will automatically pause under the following conditions:

1. Upon entering Program Mode. Datalogging will resume upon exiting Program Mode.
2. Upon entering PC Communication standby mode. Datalogging will resume upon exiting PC communication standby mode, only if datalogging mode was set to automatic.

In both cases a new datalog event will be created when the datalogging is resumed.

### 3. Operation of Accessories

The accessories for SentryRAE include:

- Battery charger
- Alkaline battery adapter
- Water trap filter and remote sampling probe
- Dilution fitting
- Calibration adapter



To reduce the risk of ignition of hazardous atmospheres, recharge battery only in area known to be non-hazardous. Remove and replace battery only in area known to be non-hazardous.

Ne charger les batteries que dans l'emplacement désigné non dangereux.

## 3.1 Battery Charging Operation

The charging circuit of the SentryRAE is built into the monitor. It requires a regular AC to 15 V DC adapter (a wall mount transformer) to charge the monitor.

1. Connect the AC adapter (or the optional automotive charging adapter) to the charger port on the bottom of the SentryRAE monitor.
2. An LED labeled "Charge" is located on the front of the instrument. A red light indicates the battery is charging. A green light indicates the battery is fully charged.
3. A completely drained SentryRAE monitor will be charged to full capacity within 10 hours.

**Note:** The rechargeable Lithium-Ion SentryRAE battery pack will slowly drain even when the monitor is off. If the monitor has not been charged for 5-7 days, the battery voltage will be low.

The factory-supplied battery is designed for up to 36 hours of normal operation, without alarm conditions or backlight usage. As the battery ages or is subjected to adverse conditions, such as cold ambient temperature, the battery capacity may significantly reduce.

## 3.2 Interchangeable Battery Packs

The Alkaline battery adapter supplied by RAE Systems Inc. is **intrinsically safe**. An alkaline battery adapter is supplied with each SentryRAE kit. It may be used in place of the rechargeable Lithium-Ion battery pack to provide at least 36-hours of operation.

The alkaline pack holds 6 C-size alkaline batteries. Use only DURACELL Mn1400 or ENERGIZER E93 C-size batteries with the SentryRAE alkaline battery pack.

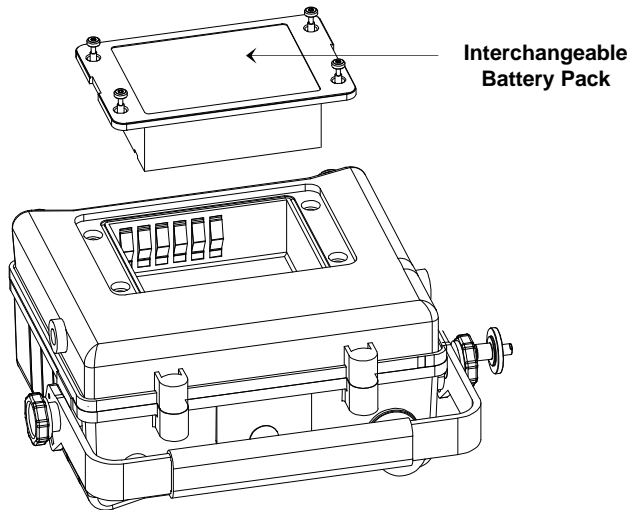

**Figure 3-1. Interchangeable Battery Packs**

### **Intrinsic Safety for Batteries**

The rechargeable Lithium-Ion and alkaline battery packs are UL Classified as Intrinsically Safe for use in the following areas:

Class 1, Division III, Groups A, B, C, and D

Class 2 Groups E, F and G

### Recharging the Lithium-Ion Battery Pack

1. Turn off power of the SentryRAE.
2. Connect the AC adapter (or the optional automotive charging adapter) to the charger connection port on the SentryRAE monitor.
3. A red “charge” LED located on the front of the instrument will indicate that the battery is being charged. A completely drained SentryRAE will be fully charged within 10 hours.

### Removing or Replacing the Alkaline Battery Adapter

1. **Before** removing or replacing the battery pack, please make sure the SentryRAE monitor is located in a non-hazardous area and is not connected to the charger.
2. To remove the battery pack, unscrew the four screws that secure the battery pack to the SentryRAE housing.
3. Remove and replace drained alkaline batteries. Use only DURACELL Mn1400 or ENERGIZER E93 C size batteries with alkaline battery pack. Be sure to match the battery polarity as indicated by the diagram inside the battery holder.
4. Reattach the battery pack to monitor.

**Note:** The internal charging circuit will automatically detect the alkaline battery adapter and will not charge the battery adapter.

### 3.3 Water Trap Filter

The external water trap/dust filter is made of a PTFE (Teflon<sup>®</sup>) membrane with a 0.2 micron pore size to prevent liquid water from being sucked into the sensor manifold, which would cause extensive damage to the monitor. It also prevents dust from entering the monitor and prolongs the sensors' operating life.

To install the water trap filter, slide the Tygon tubing onto the ribbed inlet port of the monitor. A male Luer connector fits into the female Luer of the filter. To remove the filter, disconnect the Luer connector.

There are some vapors that are especially reactive or easily absorbed by instrument surfaces; they include, but are not limited to: Cl<sub>2</sub>, PH<sub>3</sub>, NH<sub>3</sub>, HCN, and semi-volatile organic compounds like diesel fuel and jet fuel. For these compounds the high pump speed setting should be used. (See Section 2.9 Integrated Sampling Pump) It is also more desirable to use inert connecting and sampling tubing, such as Teflon<sup>®</sup> instead and to make tube connections as short as possible.

### **3.4 Remote Sampling Probe or Teflon<sup>®</sup> Tubing**

A 15-foot (5M) length of Teflon<sup>®</sup> tubing is supplied as a standard accessory with every SentryRAE detector. An optional 6-foot Teflon<sup>®</sup> remote sampling probe with a telescoping handle is also available for The user who need to probe hard-to-reach areas such as ceilings, storage tanks, underground manholes, etc.

Connect the male Luer connector to the end of the remote sampling probe or the Teflon<sup>®</sup> tubing to the female Luer connector on the water trap filter. The remote sampling probe or the Teflon<sup>®</sup> tubing is ready for operation.

## 3.5 Dilution Fitting

An optional dilution fitting can be installed with the remote sampling probe or Teflon<sup>®</sup> tubing on the gas inlet port to dilute gas samples. This fitting is needed when the gas sample contains less than 15% oxygen. The combustible sensor will not function correctly when the oxygen concentration falls below 15%. The dilution fitting will increase the oxygen concentration so the combustible sensor may still be used under oxygen deficient conditions. The dilution fitting may also be used to measure combustible, VOC or toxic gases when concentrations exceed the upper limit of the sensor range.

To use the dilution fitting, insert the fitting between the water trap filter and the remote sampling probe or Tygon tubing. Set the dilution ratio in Program Mode so the correct gas reading displays when the dilution fitting is used. (See Section 4.8.4 Change Dilution Ratio)



<p>For this application, the user must have the monitor located in a clean atmosphere outside the confined space and use a remote access probe or Teflon<sup>®</sup> tubing to measure the gas concentration.</p>
---

## **3.6 Calibration Adapter**

The SentryRAE should be calibrated with the external water trap/dust filter in place. The SentryRAE calibration adapter is designed to slip over the filter. During calibration, connect the calibration adapter to the cylinder of the calibration gas. Then insert adapter into filter and allow the gas to flow to sensors.

## 4. Programming SentryRAE

SentryRAE is built with a microprocessor to provide programming flexibility for the user. Authorized users may recalibrate the monitor, change alarm limits, change site ID, change user ID, change datalogging period, adjust the real-time clock, etc.

Program Mode is menu-based to provide user-friendly operation. The display shows menu options, and the key pad is used for menu selection and data entry.

<p><b>Note:</b> Real-time monitoring of gas concentrations continues during Program Mode. However, during calibration or when the user is reviewing Datalog data, real-time monitoring will pause until procedures are finished. In addition, when the user enters Program Mode, the datalogging operation automatically pauses. Upon exiting Program Mode, datalogging will resume.</p>
--

## 4.1 Program Mode

The SentryRAE has three user modes: **Text**, **Display** and **Program mode**. The user may access the programming function from Program Mode or from Text mode with a password; the user may not access the programming function from Display mode.

The programming function allows the user to change the setup in the monitor, calibrate the monitor, modify the sensor configuration and enter user information, etc. The programming functions are organized in a three tier menu structure.

This is the first tier of the programming menu:

- Calibrate Monitor?
- Change Alarm Limits?
- View or Change Datalog?
- Change Monitor Setup?
- Change Sensor Configuration?

Each menu item includes several submenus with additional programming functions. Refer to Appendix A for a more detailed menu structure.

### **Security Level**

There are three levels of security in the Program Mode to prevent unauthorized changes to specific settings. Security levels are set by PC. Level 0 allows the user to enter Program Mode without a password. A user may still calibrate at Level 0, however, may not change settings for alarm limits, the real-time clock, correction factors, user ID, site information, etc. Level 1 requires a four-digit password to enter Program Mode. Level 2 allows the user to enter Program Mode without any restrictions.

Once inside Program Mode, the first menu will display. Press [N/-] to view each menu option; stop until desired menu displays. To enter and display submenu, press [Y/+].

To exit Program Mode to return to normal operation, press [MODE] at any of the first tier menu options.

## 4.2 Keys for Program Mode

Key	Function
<b>[MODE]</b>	Exit menu when press momentarily or exit data entry mode when pressed and held for 1 second
<b>[Y/+]</b>	Increase numerical value for data entry Answer “yes”
<b>[N/-]</b>	Decrease numerical value for data entry Answer “no”

### 4.3 Entering Program Mode

1. Turn SentryRAE monitor on.
2. Press and hold [MODE] and [N/-] for three seconds to enter Program Mode. This prevents the user from entering Program Mode by accident.
3. Security Level 0 or Level 2 - the monitor will enter Program Mode and the first menu item "Calibrate Monitor?" will display.
4. Security Level 1 or Text mode - "Enter Password = 0000" will display with the far left digit flashing. The user enters password starting from the flashing digit.

**Note:** Prior to factory shipment, the SentryRAE monitor was installed with "0000" as the default password. For added security, "0000" is always displayed instead of the actual password.

5. If the digit value is not "0", use [Y/+ ] or [N/-] to increase or decrease digit value. Press [MODE] to confirm digit value. Display shows actual digit entered and moves the flashing cursor to the next digit to the right.
6. Repeat Step 5 until all four digits are entered. Then press and hold [MODE] for one second.
7. If the entered password is correct, the monitor enters the programming menu. The first menu item "Calibrate Monitor?" will display.
8. If the password is incorrect, the display shows "Wrong Password???" and returns to the regular display of instantaneous gas readings.
9. If the User mode is set to display mode, a message "Display Only! Cannot enter...." will be shown.

## 4.4 Calibration of SentryRAE



The calibration of all newly purchased RAE Systems instruments should be tested by exposing the sensor(s) to known concentration calibration gas before the instrument is used or put into service. For maximum safety, the accuracy of the SentryRAE should be checked by exposing the sensor(s) to known concentration calibration gas before each day's use.

In Program Mode, the user may recalibrate sensors in the SentryRAE monitor. This is a two-point calibration process using fresh air and the standard reference gas. First, fresh air, which contains 20.9% oxygen and no detectable VOC, toxic or combustible gases is used to set the zero point for each sensor. Then a standard reference gas (also known as span gas), which contains a known concentration of a given gas, is used to set the second point of reference. The two-point calibration procedure is detailed on the next page.

These are the submenus for calibration operations:

- Fresh Air Calibration?
- Multiple Sensor Calibration?
- Single Sensor Calibration?
- Modify Span Gas Value?
- Change LEL/VOC Span Gas?

### 4.4.1 Fresh Air Calibration

This procedure determines the zero point of the sensor calibration curve. To perform fresh air calibration, the calibration adapter and a bottle of fresh air (optional) are required. The bottle of fresh air contains 20.9% oxygen concentration and contains no organic, toxic or combustible gases or other impurities. If a fresh air bottle is not available, any clean ambient air without detectable contaminants may also be used. A charcoal filter should be used if purity of ambient air is unknown.

1. "Calibrate Monitor?" is the first menu item. Press [Y/+] to perform calibration. The first submenu is: "Fresh Air Calibration?"
2. If a bottle of fresh air is being used, attach the calibration adapter to the gas inlet port. Connect the other end of the tube to the bottle of fresh air. If a bottle of fresh air is not available, leave the monitor in an area free of any detectable vapors.
3. Press [Y/+] to start fresh air calibration. The display will show "zero...in progress" followed by the name of each sensor, and then the message "zeroed." The display should show a reading of "20.9" for the oxygen sensor and "0.0," or a very small number for all other sensors.
4. After a five-second pause, the display will show "Zero Cal Done!" and move to the next submenu "Multiple Sensor Calibration?"

## 4.4.2 Sensor Calibration Time

Please refer to the RAE website [www.raesystems.com](http://www.raesystems.com) and download Technical Note 114 (TN-114) Sensor Specifications and Cross Sensitivities for current data and information regarding sensor calibration time.

Slowly responding sensors listed in TN-114 may require pre-exposure of the sensor to the gas immediately before initiating the calibration sequence. Some firmware versions use a fixed 60-second calibration time; some newer versions automatically apply the full calibration time. After completing the zero calibration procedure, expose the unit to the gas for the pre-exposure time if a 60-second countdown time is programmed in the unit.

If the firmware has the full calibration time programmed in, the sensors must be calibrated in the Single Sensor mode to take advantage of this feature. The calibration time is set at 60 seconds in the Multiple Sensor mode and may not be changed.

### 4.4.3. Multiple Sensor Calibration

This function simultaneously determines the second point of calibration curve for multiple sensors in the monitor. Mixed standard reference gases are needed to perform this procedure. The user may choose several gas mixtures to be used in multiple sensor calibration.

- Continuing from Step 4 of previous section, "Multiple Sensor Calibration?" is the next display. Multiple component calibration gas mixtures are available for a number of common SentryRAE sensor configurations. Press [Y/+] to continue if a multi-component gas is being used to calibrate instrument. The display will ask user to verify which sensors will be calibrated using the multi-component mixture. Press [Y/+] to continue, or [N/-] to change choice of sensors to be adjusted.

TOX1	VOC	TOX2
CO	----	H2S
LEL	OK?	---
LEL		OXY

- Press [Y/+] to continue, and the instrument will ask user to apply gas to the sensors. Connect the Luer fitting on the calibration gas adapter to the inlet of the SentryRAE. Leave the water trap filter in place during calibration.
- Turn the regulator valve on to start the flow of gas. When the calibration gas has reached the sensor, the display will show "calibration in progress... 60", and the countdown timer will show the remaining seconds while the monitor calibrates. When the countdown timer reaches 0, the display shows the name of each sensor, the message "cal'ed!", and the calibrated values for each gas. If the sensor does not detect any gas after 60 seconds, the display will show "No gas flow..." and abort calibration.

**Note:** If the readings are very close to the span gas values, then the calibration was successful. If the readings are not close to the span gas values, then calibration has failed. Therefore, the user needs to verify that the span gas value settings in the unit match the given values on the gas bottle. (Check label on gas bottle, and also make sure gas bottle is not empty.) After a five-second pause, "Span Cal Done! Turn Off Gas" will display.

4. This completes the Multiple Sensor Calibration procedure and moves to the next submenu item, Single Sensor Calibration.
5. Turn off gas flow. Disconnect calibration tube from monitor.
6. From Step 1 of this section, if [N/-] is pressed, the display shows all the sensor names, which are selected for multiple sensor calibration with the cursor blinking at the first sensor location.

TOX1	VOC	TOX2
CO*	VOC	H2S*
LEL*	pick?	OXY
LEL		OXY

Press [Y/+] to select the sensor and [N/-] to deselect the sensor. A previously selected sensor will show an "\*" next to the sensor name. A previously deselected sensor will not show an "\*" next to the sensor name.

7. Press [MODE] to move from one sensor location to the next. Repeat Step 7 until all sensors that need to be calibrated during multiple sensor calibration have been selected. Press and hold [MODE] for one second to save the new sensor selection.
8. The "Save?" display will appear. To confirm the new selection, press [Y/+] to accept the change and continue to Step 2. Press the [N/-] or [MODE] to discard the change and to continue on with Step 2.

### **Cross Sensitivity**

Some sensors may show cross sensitivity to other gases. Therefore, it is important to choose the gas mixture carefully for the Multiple Sensor Calibration to avoid erroneous readings. For example, some VOC gases are known to cause erroneous readings by the CO sensor. In general, it is recommended to calibrate the two toxic sensors, combustible and oxygen sensor with a bottle of mixed gas using the Multiple Sensor Calibration procedure and to calibrate the PID with a bottle of a single VOC gas. Use the Single Sensor Calibration procedure for the oxygen sensor 0% O<sub>2</sub> (100% N<sub>2</sub>) calibration, if needed.

#### 4.4.4 Single Sensor Calibration

This procedure determines the second point of the sensor calibration curve for a single sensor. A standard reference gas (span gas) is needed to perform this procedure. Table 2.2 (Alarm Limits and Conditions) shows the standard calibration gas which is typically used as the span gas at the factory.

- Continuing from Step 4 or Step 6 of the previous section, the display should show "Single Sensor Calibration?" Press [Y/+]. The display shows all the installed sensors in the monitor with the cursor blinking at the first sensor location. Press [Y/+] to select the highlighted sensor and start the calibration. Or press [MODE] to move to the next sensor location.

TOX1	VOC	TOX2
CO	VOC	H2S
LEL	pick?	OXY
LEL		OXY

Turn on the valve of the CO gas bottle to start gas flow. Display shows "Apply CO Gas" and will wait for the calibration gas to reach the sensor. Once the sensor detects the gas, "Calibration in progress... 60" will appear with the countdown timer showing the remaining seconds as the monitor calibrates. When the countdown timer reaches 0, the display shows the sensor name and the calibrated value:

TOX1	VOC	TOX2
CO		cal'ed
	reading = 50 ppm	
LEL		OXY

If the sensor does not detect any gas after 60 seconds, "No gas flow..." will display and calibration will be aborted.

**Note:** The reading should be very close to the span gas value. After a five-second pause, "Span Cal Done! Turn Off Gas" will appear.

2. This completes the single gas calibration procedure for one sensor. The display shows the single gas calibration submenu for a user to select another sensor or move to the next submenu, Modify Span Gas Value.
3. Turn gas flow off. Disconnect calibration tube from monitor.
4. Repeat Step 1 through Step 3 to calibrate the next sensor.
5. Press [MODE] to stop the countdown timer and abort the calibration during Step 1. If a sensor fails calibration, the sensor name and the error message "failed, continue?" will appear. Press [N/-] or [MODE] to abort calibration and move to the next submenu item. Press [Y/+] to continue single gas calibration. In either case, the current calibration data will not be changed.

### **Oxygen Sensor Calibration**

The oxygen sensor calibration is slightly different from the other sensors. The oxygen sensor measures a range of 0 to 30% of oxygen in the air. During fresh air calibration, the oxygen sensor is calibrated to fixed 20.9% of oxygen. During single sensor calibration, the user may supply a pure nitrogen gas so the oxygen sensor may be calibrated to 0% oxygen. The user may also supply other span concentrations of the oxygen, e.g. 19.5%, to calibrate the oxygen sensor. When "0% oxygen?" appears, enter [Y/+] if the pure nitrogen gas is used to calibrate the oxygen sensor. Otherwise, enter [N/-] to calibrate the oxygen sensor to another span oxygen value. During either single or multiple sensor calibration, the oxygen sensor will be calibrated to the span value. (See Section 4.4.5 Modify Span Gas Value)

<p><b>Note:</b> After a 0% oxygen calibration, the user must perform a fresh air calibration to ensure that the oxygen sensor is calibrated correctly.</p>
--

### **Calibration Time Stamp**

When a single or multiple sensor calibration is performed, a time stamp will be stored in the non-volatile memory. This information will be included in the datalogging report.

## 4.4.5 Modify Span Gas Value

This function allows the user to change the span values of the standard calibration gases.

1. The next submenu is “Modify Span Gas Value?”
2. Press [Y/+], and the following display will appear:

TOX1	VOC	TOX2
50	100	10
50	span	20.9

LEL OXY

The blinking cursor will be on the first digit of the first span value. To modify any of the span gas values, go to Step 3. Otherwise, press and hold [MODE] for one second to accept the previously stored span gas value and advance to the next submenu, Change LEL/VOC Span Gas.

3. Starting from the far left digit of the span gas value, use [Y/+] or [N/-] to change the digit value and press [MODE] to move to the next digit to the right. Repeat until all span gas values have been entered. Press and hold [MODE] for one second to save the new calibration gas value.
4. The display shows “Save?” To confirm the new value, press [Y/+] to accept the change. Press the [N/-] or [MODE] to discard the change and move to the next calibration submenu.

## 4.4.6 Change LEL/VOC Span Gas

This function allows the user to select a specific LEL or VOC gas to be used as the span gas during LEL or VOC gas calibration.

1. When the "Change LEL/VOC Span Gas?" submenu appears, press [Y/+]. If the LEL sensor is installed and enabled, the display shows:

TOX1	VOC	TOX2
LEL Span = ?		
Methane		
LEL		OXY

Otherwise, the message "No LEL installed" will appear.

2. If the user does not want to change the LEL span gas, press [Y/+] to accept the current selection and exit this submenu.
3. If the user wants to select a different LEL span gas, press [N/-]. Then use [Y/+] or [N/-] to scroll through a list of gas names until a desired gas name appears in the LCD display, then press [MODE] to select the new gas name.
4. The display shows "Save?" To confirm the new gas selection, press [Y/+] to accept the change. Press the [N/-] or [MODE] to discard the change and move to the next display.

5. If the VOC sensor is installed and enabled, the display shows:

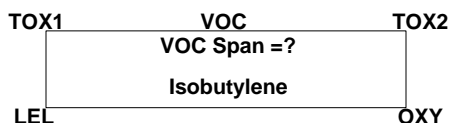

Otherwise, the message "No VOC installed" will appear.

6. If the user does not want to change the VOC span gas, press [Y/+] to accept the current selection and exit this submenu.
7. If the user wants to select a different VOC span gas, press [N/-] first then use [Y/+] or [N/-] to scroll through a list of gas names until a desired gas name appears in the LCD display, then press [MODE] to select the new gas name.
8. The display shows "Save?" To confirm the new gas, press [Y/+] to accept the change. Press the [N/-] or [MODE] to discard the change and return to the first calibration submenu.

## 4.5 Change Alarm Limits

The user may change alarm limits of each sensor while in Program Mode.

These are the submenus for changing the alarm limits:

Change High Alarm limit?

Change Low Alarm limit?

Change STEL alarm limit?

Change Average alarm limit?

1. The items in the submenu allow the user to change the high alarm limit, low alarm limit, STEL alarm limit or average alarm limit. The average alarm limit can be "Running Average" or "TWA (Time Weight Average)" depending on the menu selection on "Change Averaging Method" (see Section 4.7.8). Press [N/-] to circle through the submenu. Press [Y/+] to enter a submenu and the display shows "HIGH", "LOW", "STEL", "TWA" or "AVG" with a flashing cursor on the left-most digit of the previously stored alarm limits.

TOX1	VOC	TOX2
35	50.0	10
10	LOW	19.5
LEL		OXY

TOX1	VOC	TOX2
100	25.0	15
	STEL	
LEL		OXY

TOX1	VOC	TOX2
200	100.0	20
20	HIGH	23.5
LEL		OXY

TOX1	VOC	TOX2
35	10.0	10
	TWA	
LEL		OXY

Or if the Averaging Method is the Running Average, the AVG will display instead of the TWA. (See Section 4.7.9 Change Averaging Method)

<b>TOX1</b>	<b>1.0</b>	<b>VOC</b>	<b>10.0</b>	<b>TOX2</b>	<b>10</b>
<b>LEL</b>	<b>AVG</b>				<b>OXY</b>

2. To modify this limit, starting from the left-most digit, use [Y/+] or [N/-] to change the digit value and press [MODE] momentarily to advance to the next digit. The flashing digit will move on to the next digit to its right. Repeat this process until all the new Alarm limits are entered. Press and hold [MODE] for 1 second to exit data entry mode. If there is any change to the existing value, the display shows "Save?" Press [Y/+] to accept the new value and move to the next submenu. Press the [N/-] to discard the changes. To preserve the previously stored alarm limit, press and hold [MODE] for 1 second and the monitor will exit data entry mode and move to the next submenu.

## 4.6 View or Change Datalog

SentryRAE monitor calculates and stores the gas readings at a specified interval. The user can review these stored readings or change datalog setup from the Program Mode. The user can also program additional datalog options by downloading from the PC to the SentryRAE monitor.

These are the submenus for Datalog options:

Clear All Data?

Change Datalog Period?

Select Data Type?

Enable / Disable Datalog?

### 4.6.1 Reset Peak and Minimum

This function will reset peak and minimum data stored in the non-volatile data memory.

1. "Reset Peak and Minimum?" is the first item in the Datalog submenu.
2. Press [Y/+] to clear the peak and minimum data memory. Display shows "Are You Sure?" to re-confirm whether to reset peak and minimum data.
3. Press [Y/+] again will reset peak and minimum data.
4. Press the [N/-] or [MODE] to exit without resetting the data and move to next datalog submenu.

**Note:** STEL and TWA (or AVG) value will not be affected when peak and minimum values are reset.

## 4.6.2 Clear All Data

This function will erase all data stored in the non-volatile datalog memory. This does not change STEL, TWA, Peak, minimum concentration and run time values which are stored in the other location.

1. "Clear All Data?" is the second item in the Datalog submenu.
2. Press [Y/+] to clear the data memory. Display shows "Are You Sure?" to re-confirm the clearing of memory.
3. Press [Y/+] again will erase all the data memory.
4. Press the [N/-] or [MODE] to exit without clearing the data memory and move to next datalog submenu.

### 4.6.3 Change Datalog Period

The datalog period can be programmed from 1 to 3,600 seconds (1 hour).

1. "Change Datalog Period?" is the third item in the Datalog Program submenu item.
2. Press [Y/+], the display shows "New Period = 0060" with the left-most digit flashing, where "0060" is the previously stored data log period.
3. To modify this period, starting from the left-most digit, use the [Y/+] or [N/-] to change the digit value and press [MODE] momentarily to advance to the next digit. The flashing digit will move to the next digit to the right. Repeat this process until all 4 digits of the new period are entered. Press and hold [MODE] for 1 second to exit data entry mode. If there is any change to the existing value, the display will show "Save?" Press [Y/+] to accept the new value and exit the datalog submenu. Press the [N/-] to discard the changes and move to the next menu option.
4. To preserve the previously stored period, press and hold [MODE] for 1 second. The monitor will exit data entry mode and move to the next submenu item.

## 4.6.4 Select Data Type

The user can choose to store either the average or the peak value during each datalog period.

1. When the "Select Data Type?" submenu item appears, press [Y/+], the display shows the current data type: "Data Type = Average?"
2. If pressing [Y/+] it will accept the currently displayed data type and automatically goes into View Datalog. If pressing [N/-] it will change to the other data type: "Data Type = Peak?" Press [MODE] to exit this submenu and move on to the next submenu.
3. If there is any change to the existing selection, pressing [Y/+], the display will show "Save?" Then, press [Y/+] to accept or the [N/-] to discard and move to the next submenu.

<p><b>Note:</b> It is necessary to select "Average" data type in order to calculate the correct STEL and TWA data for datalogging report.</p>
---

## 4.6.5 View Datalog

This function allows the user to review all the data that is stored in the non-volatile data memory.

1. When the "View Datalog?" submenu item appears, press [Y/+] and the LCD display shows the first event number and start date and time of the event.

TOX1	VOC	TOX2
Event # 1?		
8/3/96 8:20		

LEL OXY

2. Press [Y/+] to review data of the first event. The LCD display shows the stored data of each sensor and the time stamp:

TOX1	VOC	TOX2
1	0.0	0
2	8:20	0.5

LEL OXY

3. Press the [Y/+] or [N/-] to move forward or backward to view other data of this event. When reaching the end or the beginning of the event, the message "Start of data!" or "End of data!" will appear. Press [MODE] to exit the current event.
4. Press [N/-] at Step 2 to see next event. If there is no more event, the message "No more event! Quit?" will appear. Press [N/-] to go back to the first event or press [Y/+] to exit and move to the next submenu.

## 4.6.6 Enable/Disable Datalog

The user can choose to enable or disable the datalogging function on each individual sensor. This allows The user to selectively log certain sensor readings of interest.

1. When the “Enable / Disable Datalog?” appears, press [Y/+]. The display shows the entire installed sensor in the monitor. A previously selected sensor to be datalogged is marked with an “\*” next to the sensor name. The cursor is blinking at the first sensor location. Press [Y/+] to enable the datalogging for the sensor and [N/-] to disable the datalogging.

TOX1	VOC	TOX2
CO*	VOC*	H2S*
LEL*	pick	OXY*
LEL		OXY

2. Press [MODE] momentarily to move from one sensor location to the next one. Repeat Step 2 until all the sensors need to be datalogged are selected. Press and hold [MODE] for 1 second to save the new sensor selection.
3. The display shows “Save?” To confirm the new selection, press [Y/+] to accept the change. Press the [N/-] or [MODE] to discard the change and return to the first datalog submenu.

## 4.7 Change Monitor Setup

In the Program Mode, the user may change monitor setup or enter user information for the SentryRAE monitor.

Monitor Setup submenu:

Change Site ID?

Change User ID?

Change Alarm Mode?

Change User Mode?

Change Real-time Clock?

Change Light and Buzzer Mode?

Change Password?

Change Pump Duty Cycle?

Change Pump Speed?

Change Averaging Method?

Change Display Language?

Set Temperature Unit?

## 4.7.1 Change Site ID

The user needs to enter an eight-digit alphanumeric site ID in the Program Mode. This site ID will be included in the datalog report.

1. "Change Site ID?" is the first submenu item. Press [MODE] to choose one of them and press [Y/+], the display shows the current site ID: "Site ID = xxxxxxxx" with the left most digit flashing.
2. Press the [Y/+] or [N/-] to cycle through all 26 letters and 10 numerals. Press [MODE] momentarily to advance to the next digit. The flashing digit will move to the next digit to the right. Repeat this process until all 8 digits of the new site ID are entered.
3. Press and hold [MODE] for 1 second to exit the data entry mode and move to the next monitor setup submenu.
4. If there is any change to the existing site ID, the display shows "Save?" Press [Y/+] to accept the new site ID and exit the monitor setup submenu. Press [N/-] to discard the changes and move to the next submenu.

## 4.7.2 Change User ID

The user can enter an eight-digit alphanumeric user ID in the Program Mode. This user ID will be included in the datalog report.

1. "Change User ID?" is the second submenu item. Press [Y/+] and the display shows the current user ID:"User ID=xxxxxxx" with the left digits flashing.
2. Press the [Y/+] or [N/-] to cycle through all 26 letters and 10 numerals. Press [MODE] momentarily to advance to the next digit. The flashing digit will move to the next digit of its right. Repeat this process until all 8 digits of the new user ID are entered.
3. Press and hold [MODE] for 1 second to exit the data entry mode and move to the next monitor setup submenu.
4. If there are any changes to the existing user ID, the display shows "Save?" Press [Y/+] to accept the new user ID and exit the monitor setup submenu. Press [N/-] to discard the changes and move to the next submenu.

### 4.7.3 Change Alarm Mode

There are two different alarm modes: latched and auto reset in SentryRAE that can be selected from the programming menu.

1. "Change Alarm Mode?" is the third submenu item. Press [Y/+], the display shows the current alarm mode selection: "Alarm Mode = Latched?"
2. Press [Y/+] to accept the currently displayed alarm mode. Press [N/-] to change to the other alarm mode: "Alarm Mode = Auto Reset?" Press [MODE] to exit this submenu and move to the next monitor setup submenu.
3. If there is any change to the existing selection, pressing [Y/+] the display will show "Save?" Then, press [Y/+] to accept or the [N/-] to discard and move to the next submenu.

## 4.7.4 Change User Mode

There are three different user modes: program, display and text in SentryRAE that can be selected from the programming menu.

1. "Change User Mode?" is the fourth submenu item. Press [Y/+], the display shows the current user mode selection: "User Mode = Program?"
2. Press [Y/+] to accept the currently displayed user mode. Press [N/-] to scroll through the other two user modes. Press [MODE] to exit this submenu and move to the next monitor setup submenu.
3. If there is any change to the existing selection, pressing [Y/+] the display will show "Disable Program! Are you Sure?" Then, press [Y/+] to accept or [N/-] to discard and move to the next submenu.

<p><b>Note:</b> If the user mode is changed to display or text mode, the user can no longer enter the programming menu. Therefore, the user cannot change the user mode back to program mode from the monitor. The only way to change the user mode back to "program" mode is to use a PC and the ProRAE-Suite program or "multicfg" program (see Section 5 for details).</p>
---

## 4.7.5 Change Real-time Clock

The SentryRAE monitor is equipped with a real-time clock. The user can enter the correct date and time into the real-time clock in the Program Mode.

1. "Change Real-time Clock?" is the fifth submenu item. Press [Y/+], the display shows both the current date and time: "Date = April 01, '02" and "Time = hh : mm" with the left most digit of the date flashing.
2. To modify this value, use the [Y/+] or [N/-] to change the digit value and press [MODE] momentarily to advance to the next digit. The flashing digit will move on to next digit to its right. Repeat this process until the new date and time values are entered. Press and hold [MODE] for 1 second to exit data entry mode. If there is any change to the existing value, the display shows "Save?" Press [Y/+] to accept the new value and move to next submenu. Press the [N/-] to discard the changes and move to next submenu.

## 4.7.6 Change Light and Buzzer Mode?

The user has the option to turn the light and buzzer on/off to suit their needs. The factory settings are saved to have both the light and buzzer turn on during alarm conditions. However, after the user changes and saves the settings, that particular setting will appear the next time the user enters this menu to change the options again.

1. At the screen “Change Light & Buzzer Mode?” press [Y/+] to view submenus. Otherwise, press [N/-] to advance to Change Password menu.
2. When the display “Light & Buzzer = Both On?” appears, press [Y/+] to accept option and advance to the Change Password menu; the light will turn on and the buzzer will sound during alarm conditions. Otherwise, press [N/-] to decline and move to the next submenu.
3. When the display “Light & Buzzer = Light Only?” appears, press [Y/+] to accept and only the light will turn on during alarm conditions. Otherwise, press [N/-] to decline and the “Light & Buzzer = Buzzer Only?” screen will appear. Press [Y/+] to accept and advance to the Change Password menu; only the buzzer will sound during alarm conditions. Otherwise, press [N/-] to decline and move to next submenu.
4. When the display “Light & Buzzer = Both off?” appears, press [N/-] to return to step 1, or press [Y/+] to accept and advance to the Change Password menu; neither the light will turn on nor the buzzer will sound during alarm conditions.

## 4.7.7 Change Password

The user can modify the password from the monitor.

1. When the screen “Change Password?” appears, press [Y/+] and the display shows the current password: “Enter new password = xxxx” with the left most digit flashing.
2. Press the [Y/+] or [N/-] to cycle through all 10 numerals. Press [MODE] momentarily to advance to the next digit. The flashing digit will move to the next digit to the right. Repeat this process until all 4-digits of the new password are entered.
3. Press and hold [MODE] for 1 second to exit the data entry mode and move to the next monitor setup submenu.
4. If there is any change to the existing password, the display shows “Save?” Press [Y/+] to accept the new password. Press the [N/-] to discard the changes and move to the next submenu.
5. Next, the monitor asks to confirm this value, “Confirm New Password = 0000” with the far left digit blinking. Reenter the number as before to exit the Monitor Setup submenu. If the number is not entered in correctly a second time, the password will revert to its original setting.

## 4.7.8 Change Pump Duty Cycle

A duty cycle is the ration of the time the pump is on for ten-second periods. A 30% duty cycle would mean that the instrument turns the pump on for three seconds, and then turns the pump off for seven seconds. Users may control the time the pump is on for the specified ten-second period. Currently, users may only set the duty cycle from 30% (three seconds) to 100% (ten seconds) with 10% (one-second) increments. Increasing the duty cycle gives the instrument more time to clean its lamp, reducing lamp contamination, which slows the rate of signal degradation.

A disabled duty cycle means the pump is always on. The pump duty cycle is disabled when the reading is higher than 2.0 ppm and is enabled when the reading drops below 1.6 ppm. Users may also disable the duty cycle by setting the duty cycle to 100%. The duty cycle is also disabled during system warm-up, PC communication mode, calibration mode, and diagnostic mode.

1. At the “Change Duty Cycle?” display, press [Y/+] to enter this menu, otherwise press [N/-] to advance to the next menu option “Change Pump Speed?”
2. Next, the screen “New Duty Cycle (30%~100%) =” will appear with a percentage value following it. If the percentage is less than 100%, then press [Y/+] to increase the duty cycle by 10%. If the percentage is greater than 30%, then press [N/-] to decrease the duty cycle by 10%.
3. Once specified value has been selected, press [MODE] for three seconds. The screen “Value Changed?” will appear. If no values have been changed, user will advance to next menu option “Change Pump Speed?”
4. If values have been changed, user may save their changes when the screen “Save?” appears by pressing [Y/+]. “Save!” will confirm changed settings have been saved.
5. If the user decides not to save changes to settings, then press [N/-] when “Save?” appears. User will advance to next menu option “Change Pump Speed?”

### **4.7.9. Change Pump Speed**

There are two speed settings for the pump motor in the SentryRAE that can be selected from the programming menu: low (default) and high. The “high” setting (400cc flow per minute) should be used for long lengths of tubing or when rapid changes in input conditions are expected. The “Low” setting (300cc flow per minute) may be selected when the operating conditions are slow to change. Low may also be used to prolong pump motor life; LEL sensor life and battery run time.

1. When the “Change Pump Motor Speed?” display appears, press [Y/+], the display shows the current pump speed selection: “Pump Speed = Low?”
2. Press [Y/+] to accept the currently displayed pump speed and move to the next monitor setup submenu. Press [N/-] to change to the other speed “Pump Speed = High?” Press [MODE] to exit this submenu and move to the next monitor setup submenu.

## 4.7.10 Change Averaging Method

There are two methods of calculation used in the averaging of the monitor. Using this selection can cause the calculation to be performed using an eight-hour time weighted average (TWA), the default, or a running average (AVG). The display indicator for whichever averaging type is selected will show on the LCD display wherever the average is indicated.

1. When the "Change Averaging Method?" screen appears, press [Y/+], the display shows the current average selection: "Average Type = TWA?"
2. If pressing [Y/+] it will accept the currently displayed type and automatically goes into Change Site ID. If pressing [N/-] it will change to the other selection: "Average Type = Running Average?" and [Y/+] to select.
3. If there is any change to the existing selection, pressing [Y/+] the display will show "Save?" Then, press [Y/+] to accept or [N/-] to discard and move to the first setup submenu.

## 4.7.11 Change Display Language

Users may choose to view the display menus in Spanish. Additional languages will be added in the future.

1. When the “Change Display Language?” screen appears, press [N/-] to keep the language setting in English. User will advance to next menu option “Set Temperature Unit?”
2. To switch language to Spanish, press [Y/+] to enter submenu “Change Language = Spanish”. Press [Y/+] again to confirm selection. User will advance to next menu option “Set Temperature Unit?” Otherwise, press [N/-] to return to step 1.

## 4.7.12 Set Temperature Unit?

The user may change the temperature unit from Fahrenheit to Celsius (factory setting), or back to Fahrenheit from Celsius.

1. At the “Set Temperature Unit?” display, press [Y/+]. The next screen to appear will either be “Temperature Unit = Fahrenheit?” or “Temperature Unit = Celsius?”
2. Press [N/-] to toggle between units of measurement. Then press [Y/+] when desired unit appears on screen.
3. When the “save?” screen appears, press [Y/+] to accept new settings and advance to the next menu option Change Sensor Configuration. Or press [N/-] to go back to step 1.

## 4.8 Change Sensor Configuration

In the Program Mode, the user may change several sensor related configurations of the SentryRAE monitor. The Sensor Configuration Submenu contains the various configurations:

Change LEL/VOC Gas Selection?

Enable / Disable Sensors?

Change Dilution Ratio?

Change PID Lamp Type?

Before these submenus are described, the term "Correction Factor" needs to be explained:

## 4.8.1 Correction Factor

The PID and LEL sensor used in SentryRAE are broad band sensors (i.e., they respond to a broad range of gases). Typically, these sensors show a different sensitivity to different gases. The correction factor for a specific gas is defined as:

$$\text{Correction Factor} = \frac{\text{Sensitivity to a calibration gas}}{\text{Sensitivity to a specific gas}}$$

Correction factors are often used to obtain a calculated concentration of a specific gas while using a different gas during calibration.

The SentryRAE monitor store three sets of correction factors: One for the LEL sensor, one for the 10.6 eV PID sensor and the other for the 11.7 eV PID sensor. Each set consists of 20 to 40 different gases. The user can choose one gas from the list to be the calibration gas and another gas to be the measurement gas.

For example, the user can choose methane as the calibration gas for the LEL sensor and select pentane as the measurement gas. The SentryRAE monitor will calculate the correction factor between these two gases and convert the measured value of the LEL sensor into equivalent concentration of the pentane gas.

Similarly, the user can choose one VOC gas for calibration and choose another VOC gas for measurement. In addition, the correction factor is different for the PID sensor due to different energy of the UV lamp used in the PID sensor. The user needs to choose the correct type of UV lamp (10.6 eV or 11.7 eV) for the PID sensor in Section 4.8.5 Change PID Lamp Type.

## 4.8.2 Change LEL/VOC Gas Selection

This function allows The user to choose one of the pre-stored LEL or VOC gases in the monitor and calculate its correction factor relative to the LEL or VOC calibration gas. This factor will then be used during gas measurements to show the equivalent concentration of the selected LEL or VOC gas. The user can also modify this relative correction factor to increase or decrease the gas reading. This allows the user to create a custom factor for a specific gas or mixture of gases.

1. "Change LEL/VOC Gas Selection?" is the first submenu item. Press [Y/+]. If an LEL sensor is installed and enabled, the display shows:

TOX1	VOC	TOX2
LEL Gas =?		
Methane		
LEL		OXY

Otherwise, the message "No LEL installed" will be displayed and skip to Step 8.

2. If the user does not want to change the LEL measurement gas, press [Y/+] to accept the current gas and skip to Step 6.
3. If the user wants to modify the LEL measurement gas, press [N/-] first, then use [Y/+] or [N/-] to scroll through a list of gas names until the desired gas name appears in the LCD display, then press [MODE] to select the new gas name.
4. The display shows "Save new gas?" To confirm the new gas, press [Y/+] to accept the change. Press the [N/-] or [MODE] to discard the change and move to the next step.

5. "1.00" is the calculated correction factor of the selected gas in Step 4.

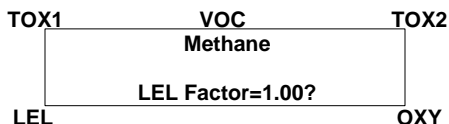

6. If the user does not want to modify the LEL correction factor, press [Y/+] and go to Step 8. To modify this factor, press [N/-] first. Then starting from the left-most digit, use the [Y/+] or [N/-] to change the digit value and press [MODE] momentarily to advance to the next digit. The flashing digit will move on to next digit to its right. Repeat this process until all 4 digits of the new factor are entered. Press and hold [MODE] for 1 second to exit data entry mode. If there is any change to the existing value, the display shows "Save?" Press [Y/+] to accept the new value and exit the gas selection submenu. Press the [N/-] to discard the changes.
7. If the VOC sensor is installed and enabled, the display will show:

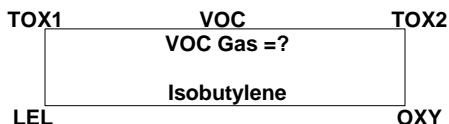

Otherwise, the message "No VOC installed" will be displayed and move to the next submenu.

8. If the user does not want to change the VOC measurement gas, press [Y/+] to accept the current gas and go to Step 12.
9. If the user wants to modify the VOC measurement gas, press [N/-] first, then use [Y/+] or [N/-] to scroll through a list of gas names until the desired gas name appears in the LCD display, then press [MODE] to select the new gas name.
10. The display shows "Save?" To confirm the new gas, press [Y/+] to accept the change. Press the [N/-] or [MODE] to discard the change and move to the next step.

11. "1.00" is the calculated correction factor of the selected gas in Step 10.

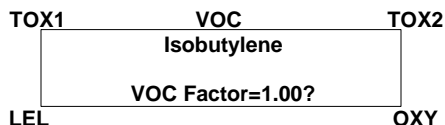

12. If the user does not want to modify the VOC correction factor, press [Y/+] and exit the submenu. To modify this factor, press [N/-] first. Then starting from the left-most digit, use the [Y/+] or [N/-] to change the digit value and press [MODE] momentarily to advance to the next digit. The flashing digit will move on to next digit to its right. Repeat this process until all 4 digits of the new factor are entered. Press and hold [MODE] for 1 second to exit data entry mode. If there is any change to the existing value, the display shows "Save?" Press [Y/+] to accept the new value and exit the gas selection submenu. Press the [N/-] to discard the changes.

### 4.8.3 Enable/Disable Sensor

This function allows the user to selectively enable or disable individual sensors in the SentryRAE monitor. When a sensor is disabled, the sensor will not measure nor display the gas concentration.

1. "Enable / Disable Sensors?" is the second submenu. Press [Y/+]. The display shows all the installed sensors in the monitor. A previously enabled sensor is marked by an "\*" next to the sensor name. The cursor will blink at the first sensor location. Press [Y/+] to enable the sensor and [N/-] to disable the sensor. A previously disabled sensor will show "----" instead of the sensor name.

TOX1	VOC	TOX2
CO*	VOC*	H2S*
LEL*	pick	OXY*
LEL		OXY

2. Press [MODE] momentarily to move from one sensor location to the next one. Repeat Step 2 until all the sensors which need to be enabled are selected. Press and hold [MODE] for 1 second to save the new sensor selection.
3. The display shows "Save?" To confirm the new selection, press [Y/+] to accept the change. Press the [N/-] or [MODE] to discard the change and move to the next submenu.

## 4.8.4 Change Dilution Ratio

The user can insert an optional dilution fitting on the SentryRAE gas inlet port to dilute the gas sample. The user can enter a dilution ratio (from 1 to 10) from the programming menu so that the reading can be compensated to show the actual concentration of the gas sample with the dilution fitting.

1. "Change Dilution Ratio?" is the third submenu item. Press [Y/+], the display shows the current dilution ratio: "Dilution Ratio = xx" with the left most digit flashing.
2. Press the [Y/+] or [N/-] to increase or decrease the value of the digit. Press [MODE] momentarily to advance to the next digit. The flashing digit will move to the next digit to the right. Repeat this process until both digits of the new dilution ratio are entered.
3. Press and hold [MODE] for 1 second to exit the data entry mode and move to the next submenu.
4. If there is any change to the existing dilution ratio, the display shows "Save?" Press [Y/+] to accept the new ratio and exit the submenu. Press the [N/-] to discard the changes and move to the next submenu.

## 4.8.5 Change PID Lamp Type

This programming menu only applies to the monitor, which is equipped with a PID detector option. There are two different energy UV lamps available for the PID sensor: 10.6 eV and 11.7 eV. The user must select a lamp in order for the instrument to calibrate correctly.

1. "Change PID Lamp Type?" is the fourth submenu item. Press [Y/+], the display shows the current PID lamp selection: "PID Lamp = 10.6 eV?"
2. Press [Y/+] to accept the currently displayed PID lamp and automatically goes into Change LEL/VOC Gas Selection. Press [N/-] to switch to the other lamp. Press [MODE] to exit this submenu and return to the first submenu.
3. If there is any change to the existing selection, pressing [Y/+] the display will show "Save?" Then, press [Y/+] to accept the [N/-] to discard and return to the first submenu.

## 4.9 Exit Program Mode

To exit Program Mode from the first tier menu level, press [MODE] once.

1. Display shows an instantaneous reading of normal operation mode.
2. To exit Program Mode from 2nd tier submenu level, press [MODE] twice.
3. To return to Program Mode, press and hold down both [MODE] and [N/-] for 3 seconds.



## 5.0 Theory of Operation

The SentryRAE monitor uses one to five different sensors to measure a variety of gases. A newly developed Electrodeless discharge UV lamp is used as the high-energy photon source for the PID sensor (see Figure 5-1). The patented PID sensor will detect a broad range of organic vapors. Up to two electrochemical toxic gas sensors can be installed in the monitor to measure inorganic toxic gases. Many different types of toxic sensors are offered. They can be plugged into these two sensor sockets and are interchangeable. A catalytic bead sensor is used to measure combustible gases. An electrochemical sensor is used to measure oxygen concentration.

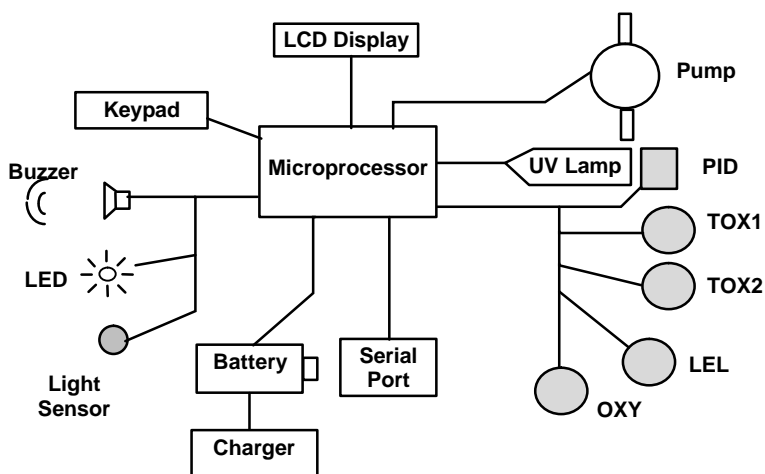

Figure 5-1 Block Diagram of SentryRAE Monitor

## THEORY OF OPERATION

---

The PID sensor for this SentryRAE monitor is constructed as a small cavity in front of the UV lamp. The other sensors are mounted next to the PID sensor. A diaphragm pump is installed inside the monitor enclosure to draw air sample into the sensor manifold and then distributed to all sensors.

A single chip microprocessor is used to control the operation of the alarm buzzer, LED, pump and light sensor. It measures the sensor readings and calculates the gas concentrations based on calibration to known standard gases. The data is stored in non-volatile memory so that it can be sent to a PC for record keeping. RS-232 transceivers provide a serial interface between the monitor and the serial port of a PC. A 2-line by 16-character LCD display is used to show the readings. The user interacts with the monitor through three keys on the front panel keypad.

A rechargeable lithium ion battery or a six C cell alkaline battery pack powers the monitor.

**Note:** The printed circuit board of the monitor is connected to the battery pack even if the power is turned off. Therefore, it is very important to disconnect the battery pack before servicing or replacing sensors or any components inside the monitor. Severe damage to the printed circuit board may occur if the battery pack is not disconnected before servicing the unit.

## 6. Maintenance

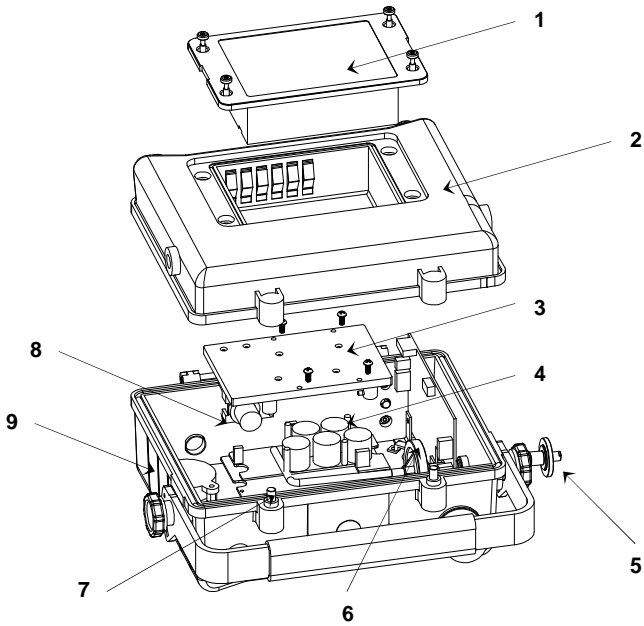

**Figure 6-1** Main Components of SentryRAE

1. Battery Pack
2. Housing (Back)
3. Gas Plate
4. Sensors
5. Water Trap
6. Internal Water Trap filter
7. Case Screw
8. Pump
9. Housing (Front)

## 6.1 Battery Replacement

When the display shows a flashing message “Bat”, the battery requires recharging. The battery may be replaced in the field (in area known to be non-hazardous) if required. It is recommended to recharge the SentryRAE monitor upon returning from fieldwork. A fully charged battery powers an SentryRAE monitor for up to 36-hours continuous operation. The charging time is less than 10-hours for a fully discharged battery. The built-in charging circuit is controlled by two-step constant voltage / constant current charging to prevent over-charging.



To reduce the risk of ignition of hazardous atmospheres, recharge battery only in area known to be non-hazardous. Remove and replace battery only in area's known to be non-hazardous.

## 6.2 Sensor Replacement

The toxic, combustible and oxygen sensors all have an expected operating life. Under normal operating condition, most sensors will lose their original sensitivity after the expected operating life and will need to be replaced.

Each sensor module in SentryRAE includes a non-volatile memory, which records the manufacturing date of the sensor. In the diagnostic mode, the microprocessor will check the date code and display the expiration date of each sensor. It is suggested that the user should replace the sensor when the current date exceeds the expiration date of a sensor.

### Sensor Replacement Procedure

The oxygen and combustible sensor each has their unique sensor sockets in the SentryRAE monitor. The two toxic sensor sockets in the SentryRAE monitor allow the user to plug in any two sensors selected from the series of toxic sensors offered by RAE Systems Inc.

1. Turn SentryRAE off.
2. Remove the battery pack. (See Section 3.2 Interchangeable Battery Packs)
3. Refer to Figure 6-1, open the monitor housing by unscrewing the two captured hex screws from the top of the monitor case.

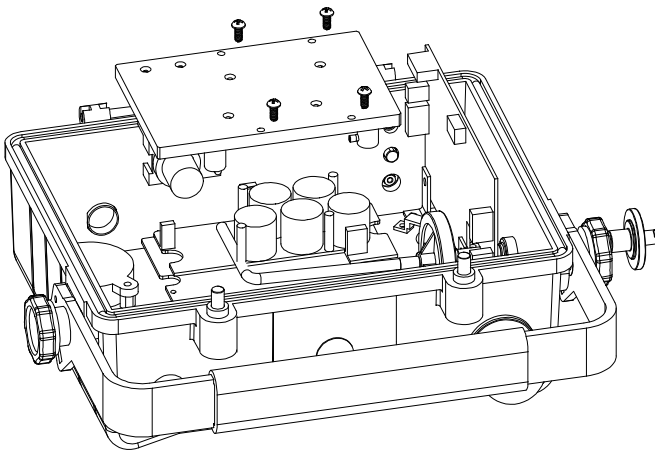

**Figure 6-2** Sensor Compartment of SentryRAE

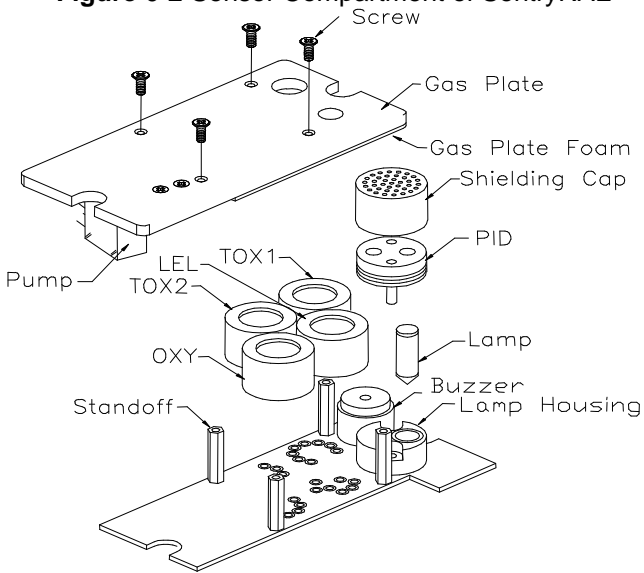

**Figure 6-3** Detailed Sensor Assembly of SentryRAE

4. Refer to Figures 6-2 and 6-3, carefully unscrew the four No.2 screws that hold down the gas piping plate to the analog PCB and sensors. Remove the gas piping plate.
5. Identify the location of a specific toxic sensor and remove the sensor by gently pulling the sensor upward.
6. Plug a new sensor into the empty sensor socket. Make sure that black line on the sensor label is lined up with the white marker on the PCB and the sensor pins are aligned with the socket before pushing down the sensor.
7. Replace the gas piping plate and tighten the four screws to hold down the sensors. Re-connect the battery pack. Replace the monitor cover.
8. Turn SentryRAE on. The microprocessor will automatically recognize the sensors installed and configure the monitor accordingly.

### **Special Bias Voltage for Toxic Sensors**

The NO and NH<sub>3</sub> toxic sensors require a special 300 mV bias voltage to operate. Only the first toxic sensor socket provides such a special bias voltage. Therefore, NO or NH<sub>3</sub> toxic sensors must be installed into the first toxic sensor socket (Tox1) in SentryRAE.

In addition, there is a dip switch or pin jumper located on the analog PCB next to the PID sensor. When an NO or NH<sub>3</sub> toxic sensor is plugged into the first toxic sensor socket, it is necessary to switch the jumper to the right to enable the bias voltage. During power on sequence, the microprocessor will check the sensor ID and the bias voltage. If the NO or NH<sub>3</sub> sensor is plugged into the wrong toxic sensor socket or the jumper is not switched on, an error message will be displayed.

## 6.3 PID Sensor Cleaning

This section only applies to a monitor that is equipped with the PID detector option. During the course of normal operation, a film of gas vapor may build up inside the PID sensor module and the UV lamp. The rate at which the film develops depends on the type and concentration of the vapors being sampled. As a guide, it is recommended to clean the PID sensor module and lamp only when the PID is malfunctioning.

The sensor module is made of several components and is attached to the lamp housing unit as shown in Figure 6-2.

If the lamp does not turn on, the monitor will display an error message of "Lamp" to indicate cleaning or replacing of the lamp is required. Periodic cleaning of the lamp window will also remove film deposits and restore lamp sensitivity. Care must be exercised when cleaning the window surface so that it will not be damaged.

1. Turn off the SentryRAE, make sure it has been disconnected from the battery charger, and then remove the battery pack.
2. Refer to Figure 6-1; open the monitor cover by unscrewing the two hex screws holding the housing together from the top of the monitor case.
3. Refer to Figures 6-2 and 6-3; carefully unscrew the four No.2 screws that hold down the gas piping plate to the analog PCB and sensors. Remove the gas piping plate.
4. Remove the shielding cap for the PID sensor. Gently pull out the PID sensor. Note the sensor is made of Teflon and stainless steel material.

## MAINTENANCE

---

5. Dip the entire PID sensor into GC grade methanol. It is highly recommended that an ultrasound bath to be used to clean the sensor for at least 3 minutes. Then dry the sensor thoroughly.
  6. If the lamp is operational, use a cotton swab to clean the flat window surface with GC grade methanol. If the lamp does not turn on remove the UV lamp.
  7. Install a new lamp, avoiding contact with the flat window surface.
  8. Reinstall the PID sensor. Install the shielding cap.
  9. Refer to Figures 6-2 and 6-3, install the gas piping plate and tighten the four screws to hold down the sensors.
  10. Replace the two hex screws holding the instrument housing together.
  11. Reinstall the battery pack.
- Calibrate the instrument prior to placing it back into service.

## 6.4 Taking Care of the Lamp

The UV lamp is made of a glass envelope and a UV window on one end of the envelope. The inside of the lamp is filled with low pressure gases. To turn on the lamp, a high voltage electric field is applied from the outside of the glass envelope. The molecules inside the lamp are ionized and produce a glow discharge effect to generate the UV light. Because this UV lamp does not have an electrode inside the glass envelope, it requires a small amount of ions inside the lamp to initiate the glow discharge process.

If the UV lamp has not been used for a long period of time (> 1 month), the ion count inside the lamp will become low. It may be slightly harder to turn on the UV lamp for the first time. If such a condition occurs, an error message "Lamp" will appear in the monitor display during the power on sequence. This phenomenon is more significant in 0.25" UV lamps used in the SentryRAE, because of the relatively small lamp size.

To solve this problem, turn on and off the monitor a few times and the lamp should turn on. Gently shaking the monitor will also help to initiate the glow discharge process. After the UV lamp is turned on for the first time, it should be easier to turn on the UV lamp next time.

SentryRAE has a built-in sensing mechanism to monitor the status of the UV lamp. If the UV lamp is not on, the error message "Lamp" will be displayed. It is possible that the UV lamp is actually on when the lamp error message appears. When the UV lamp becomes old, changed, or the configuration file inside the SentryRAE has been totally over-written, the threshold level to determine lamp failure may be wrong and cause a false alarm. To eliminate such possibility, apply some VOC sense by putting a marker close to the inlet of the SentryRAE and see if the VOC raw count can go up. If the UV lamp is on while the error message persists, then it is necessary to adjust the lamp threshold. Please refer to Chapter 7 on adjusting the threshold level for the UV lamp.

If chemical liquid or dust has been sucked into the unit. Clean the lamp window surface by wiping it with anhydrous methanol using a cotton swab. Rub in a circular motion at moderate pressure. After cleaning, hold the lamp up to the light at an angle to detect any remaining film. Repeat the process until the lamp window is clean.

### **CAUTION!**

<p>Never touch the window surface with fingers or anything which may leave a film. Water will degrade window surfaces, especially the 11.7 eV lamp window.</p>
--

## 6.5 Sampling Pump Replacement

The sampling pump is positive displacement piston pump. When approaching the end of the specified lifetime of the pump, it will consume higher amount of energy and reduce its sample draw capability significantly. When this occurs, it is necessary to replace the pump.

1. Turn off the SentryRAE, and remove the battery pack.
2. Refer to Figures 6-1, 6-2 and 6-3. Remove the two hex screws holding the instrument housing together, then carefully unscrew four No. 2 screws that hold down the gas piping plate to the analog PCB and sensors. Remove the gas piping plate.
3. Carefully loosen the connector. Unscrew the two screws that hold the pump assembly to the gas plate. Unscrew the two screws that holding the pump to the PCB. Disconnect the Tygon tubing that connects the pump to the gas inlet port.
4. Replace with a new pump assembly. Connect the Tygon tubing to the gas inlet port. Reattach the pump and screw down the pump assembly to the analog PCB.
5. Replace the gas piping plate and tighten the four screws to hold down the sensors.
6. Reattach the hex screws holding the instrument housing together, and reinstall the battery pack.

### Internal Water Trap Filter

The internal water trap filter's function is to prevent dust and moisture from entering the sensors as well as the pump. By replacing the internal water trap filter routinely, it can reduce cost of maintenance on the pump or replacement of the sensors.

The internal water trap filter should be changed when build-up of water droplets or dust is observed. To change the internal water trap filters, pull apart the lock connections and replace the filter.

## 7. Troubleshooting

To aid the user in diagnosing the monitor, the monitor has a diagnostic mode that can display critical, low level parameters. Section 7.1 describes the Operation of the Diagnostic Mode. Section 7.2 summarizes possible encountered problems and suggested solutions. If the user turns the SentryRAE monitor on in Diagnostic Mode and refers to the table in Section 7.2, the user can usually narrow the problem down and correct it without having to return the monitor for repair.

### **WARNING**

The diagnostic mode allows the user to set several low level parameters which are very critical to the operation of the monitor. Extra care should be taken when setting these low level parameters. If the user are not familiar with these parameters and set them incorrectly, it may cause the monitor to shut down or malfunction. The diagnostic mode should be used by qualified personnel only.

## 7.1 Diagnostic Mode

To place the monitor into the special diagnostic mode, first turn the monitor off. Next simultaneously push and hold [Y/+] and [MODE] for at least two seconds. After the required delay, release both keys, the monitor will now go through the normal start-up display sequence and display a “Diagnostic mode” message. At the end of the special mode start-up, the display will show 1 to 5 numbers with a message “Raw.” These numbers are raw sensor readings without calibration.

Other critical parameters of the monitor are available as shown in Table 7.1. They can be reached by pressing the [MODE] repeatedly until the desired parameters are displayed.

<b>Table 7.1 Critical Parameters</b>	
<b>Key Action</b>	<b>Display</b>
	Show Raw Readings
[MODE]	RF Test - Paused
[MODE]	Adjust PID lamp failure threshold*
[MODE]	Show battery type and Tox1 bias
[MODE]	Show x1 and x10 range of PID sensor*
[MODE]	Adjust LCD contrast
[MODE]	Check LEL power on/off
[MODE]	Show clock, battery voltage and temperature
[MODE]	Show LEL & OXY sensor expiration date
[MODE]	Show TOX1 & TOX2 sensor expiration date
[MODE]	Adjust pump stall threshold
[MODE]	Alarm code
[MODE]	Show serial number and toggle pump speed
[MODE]	Show battery duration time
[MODE]	Communicate with PC?

**\*Note:** Displays only apply to the monitor that is equipped with the PID detector option.

Diagnostic displays and how to interpret the displayed values:

### 1. Raw Sensor Readings

The raw sensor readings provide a quick diagnose on the response and the sensitivity of each sensor. When zero gas (fresh clean air) is applied to the monitor, the raw sensor readings typically should be between 200 to 700 for toxic and VOC sensors, between 100 to 1300 for LEL sensors and between 800 to 2300 for oxygen sensor. If the raw reading is outside these ranges when zero gas is applied, the sensor or the electronics may be defective.

When a specific gas is applied to the monitor, the corresponding sensor should respond and the raw reading should increase or decrease. If the reading of the corresponding sensor does not change when the specific gas is applied, then the sensor may be defective.

TOX1	VOC	TOX2
365	360	373
530	RAW	1223
LEL		OXY

### 2. Sensor Name

All the toxic, oxygen and LEL sensors have a non-volatile memory which contains the sensor identification and other vital information, such as manufacturing date, expected operating life, etc. If a sensor is programmed and installed properly in the monitor, the sensor name should be displayed. If the sensor name does not show up in the display, then the sensor may not be programmed properly or may be defective.

### 3. Adjust Lamp Failure Threshold

This diagnostic menu only applies to the monitor which is equipped with a PID detector option. This display can be used to calibrate the PID lamp failure threshold. If the lamp appears to be good but in normal operation a lamp failure message (i.e. "Lamp") is displayed, the lamp failure level may be set too high. This level can be adjusted by using the following steps:

- a. Turn the monitor off.
- b. Remove the UV lamp of the PID sensor, then replace the sensor and cover.
- c. Turn on the monitor in the special diagnostic mode.
- d. Press [MODE] until "Lamp = xxx, Fail = yyy +/-" is display. The reading "xxx" is the lamp current reading when the lamp is off. The value "yyy" is the threshold value which determines when the lamp fails.
- e. Push the [Y/+] or [N/-] to increase or decrease the threshold value "yyy" until it is about 10 counts above the "xxx" value. This will optimally set the lamp failure threshold. Press [MODE] to exit this display. If the threshold value is changed, a message "Save new lamp threshold?" will appear. Press [Y/+] to confirm the change, [N/-] or [MODE] to abandon the changes.
- f. Turn the monitor off and replace the lamp.
- g. Turn on the monitor in diagnostic mode again and press [MODE] until "Lamp = xxx, Fail = yyy +/-" is display. This time, the reading "xxx" is the lamp current reading when the lamp is on and it should be higher than the threshold value "yyy" by at least 15-20 counts. If not, the lamp may be defective or very weak.

In most cases lamp failure threshold adjust is not required, in which case the user should press [MODE] to exit this display.

### **4. Battery Type and Bias Display**

For some toxic sensors (such as nitric oxide or ammonia sensor), a bias voltage of a few hundred millivolts is required for the sensor to function properly. In the SentryRAE monitor, the user needs to manually switch the jumper to the ON position, located on the analog PCB. For this test to work, a nitric oxide or ammonia sensor has to be installed in the toxic #1 socket. If the bias voltage is switched to ON position, the bias reading should be below 182; otherwise the bias supply may be defective.

Either a rechargeable Lithium-Ion battery pack or an alkaline battery adapter can power the SentryRAE monitor. This display also shows the type of battery that is installed inside the monitor.

### **5. Show x1 and x10 Range of PID Sensor**

This diagnostic menu only applies to the monitor, which is equipped with a PID detector option. The PID sensor output is connected to two amplifiers with two different gains: unity gains and gain of ten. Raw outputs of both amplifiers are displayed. When zero gas is applied, both amplifier outputs should be between 200 to 500. When a VOC gas is applied, both amplifier output should increase and the amount of increase for the unity gain (x1) amplifier should be about 1/10 of the increase for the gain of ten (x10) amplifier. If the increase does not agree with expected value, then the gain switch of the amplifier may be defective.

### **6. Adjust LCD Contrast**

This display allows the user to adjust the LCD contrast. Press [Y/+] to increase the contrast and [N/-] to decrease the contrast. The bar graph shows the current LCD contrast setting. If the display appears having dark lines, press [Y/+] several times should see a more clear display.

### **7. Check LEL Power ON/OFF**

This display shows the present condition of the LEL sensor power and raw reading. The top display shows the instantaneous reading of raw counts from the LEL sensor. The bottom line shows if the LEL sensor is powered. By pressing [N/-] the power can be turned off. [Y/+] turns powers to the LEL on.

### **8. Show Clock, Battery and Temperature**

This display shows the real-time clock, battery voltage in raw count and temperature sensor reading.

### **9. Sensor Expiration Date**

This display shows the expiration date (month and year) of all the installed sensors in the SentryRAE monitor. The expiration date is calculated based on the manufacturing date and expected life of each sensor, which is stored inside each sensor when it was fabricated in the factory. If the current date exceeds the expiration date of any sensor, the performance of the given sensor can no longer be guaranteed. It is strongly recommended that the user replace the sensor immediately to ensure proper operation of the sensor.

### **10. Adjust Pump Stall Threshold**

This display can be used to calibrate the pump stall threshold. If the gas inlet is blocked but the pump does not shut down, or the pump shut down too easily with a slight blockage to the gas inlet, then the pump stall threshold value may be set too high or too low. Use the following steps to adjust the pump stall threshold.

- a. The maximum and average pump current is displayed on the first row: "Pump = xxx/zzz." The current pump stall value is displayed on the second row: "Stall = yyy +/-." The typical maximum pump current without any blockage should be between 20 – 35 when the speed is set to be "low" and the water trap filter is installed. The typical stall value should be higher than the "un-blocked" pump current by at least 5-8 counts.

- b. The user can block the gas inlet for about ten seconds and watch the pump current reading. The stall threshold should be set to be the average of the idle reading and the block reading. That is:  $\text{Stall} = (\text{Idle} + \text{Block}) / 2$ . The readings to be used in the calculation are maximum pump current readings at the “xxx” location of the unit.
- c. Use [Y/+] or [N/-] to increase or decrease the stall value until it is the average of the idle reading and the block reading. Press [MODE] to exit this display. If the threshold value is changed, a message “Save new stall threshold?” will appear. Press [Y/+] to confirm the change, [N/-] or [MODE] to abandon the changes.
- d. The pump stall threshold should be re-adjusted if the pump speed is switched to “low” or “high,” or water trap filter changed, or the firmware configuration has been totally refreshed.

### **11. Serial Number and Pump Toggle**

This display shows the unit’s serial number. If a pump is installed and pump speed control circuit available, the display “Pump = Low/High” may be toggled by pressing [N/-]. Note that changes made here are only for testing the pump condition and do not become saved in the nonvolatile memory. (See Section 4.7.9 Change Pump Speed Setting)

### **12. Display Battery Duration Time**

This display shows the run time of the last time the unit powered itself off due to a low battery. It is useful for battery life testing.

### **13. Communicate with PC?**

This display give the option of communicate with the PC for upload or download activity.

## 7.2 Possible Problems & Solutions

<b>Problem</b>	<b>Possible Reason</b>	<b>Possible Solution</b>
No power after charging battery	Drained battery Defective battery Microprocessor hang-up	Charge battery Replace battery Disconnect then reconnect battery to reset computer
No LED or LCD backlight	Defective LED or LCD backlight	Call authorized service center
Lost password	Forgot password	Call authorized service center
Buzzer inoperative	Defective buzzer	Call authorized service center
Reading abnormally high	Wrong calibration data Dirty sensor module Dirty water trap filter Excessive moisture and/or water condensation	Calibrate with gas again Clean sensor module Replace water trap filter Blow dry sensor module
"Lamp" message during operation	Wrong threshold Dirty PID sensor Weak or defective PID lamp	Adjust lamp threshold Clean PID sensor Replace PID lamp
Reading abnormally low	Incorrect calibration Low sensitivity to the specific gas	Calibrate monitor Replace sensor
Read a small background value when there is no detectable gas	Sensor zero drifted The unit was out of battery power connection or the sensor just plugged in	Do fresh air calibration (see section 4.4.1) Wait for reading to be stabilized

(Continued)

## TROUBLESHOOTING

---

<b>Problem</b>	<b>Possible Reason</b>	<b>Possible Solution</b>
Reading jumps around randomly	Incorrect gas calibration Low sensitivity to calibration gas	Calibrate the sensor Clean PID Check Sensor
Cannot turn monitor off Corrupted characters on LCD	Microprocessor hang-up	Disconnect and reconnect battery to reset computer Call authorized service center
Calibration error message	No standard gas input	Make sure standard gas flows into monitor
"Bat" message in operation	Uncharged battery	Recharge battery
Full scale measurement in humid environment	Dirty or wet sensor	Clean and dry sensor Replace water trap filter
VOC measurement maxes out at certain level	Dirty PID sensor module Weak PID lamp	Clean lamp/sensor module Release with a new lamp Replace filter
Excessive pump noise No inlet air vacuum	Leaky inlet path Defective pump	Check inlet connection Replace with a new pump



# Navigation Guide

M: Press [MODE]

M+Y: Press [MODE] and [Y/+] together

M+N: Press [MODE] and [N/-] together

M5: Press [MODE] for more than 3 seconds, then countdown for 5 seconds

\* If the unit is turned on in Diagnostic Mode, the user may switch between Diagnostic Mode and Normal Mode, by pressing [MODE] and [Y/+] together.

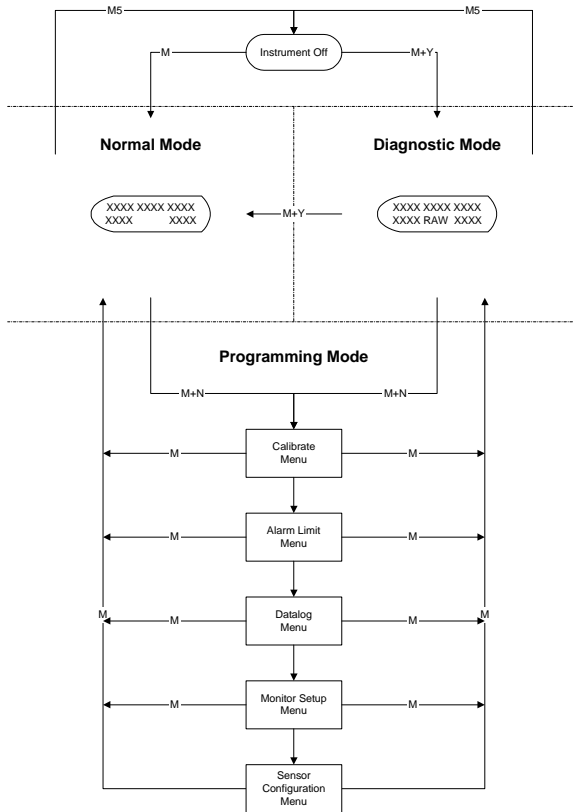

## Normal Mode: Display Menu

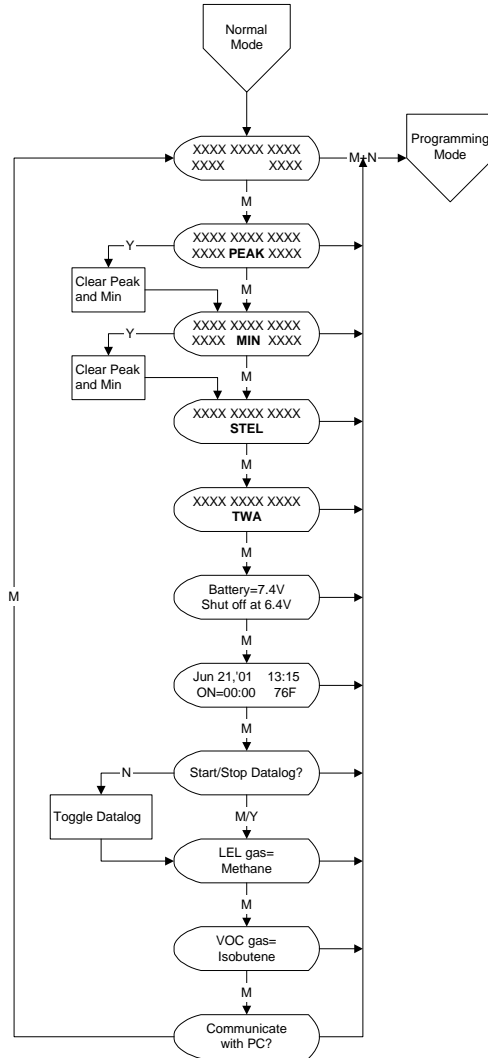

## Diagnostic Mode: Display Menu

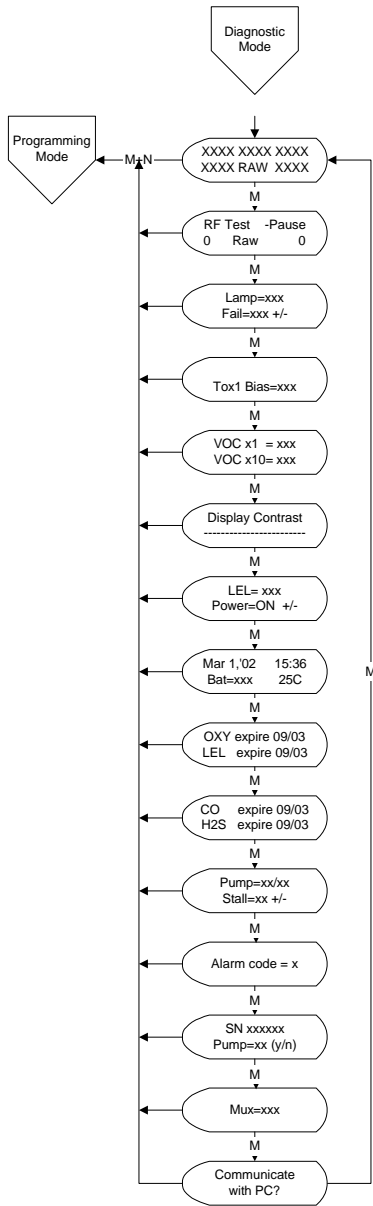

## Program Mode: Calibration Menu

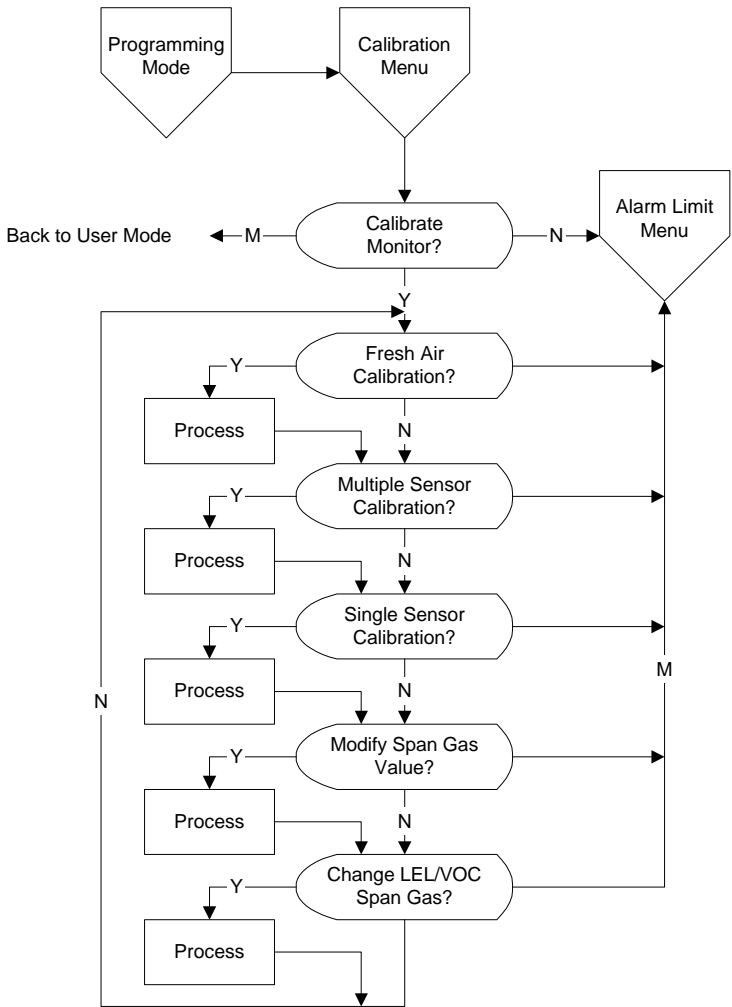

## Program Mode: Alarm Limit Menu

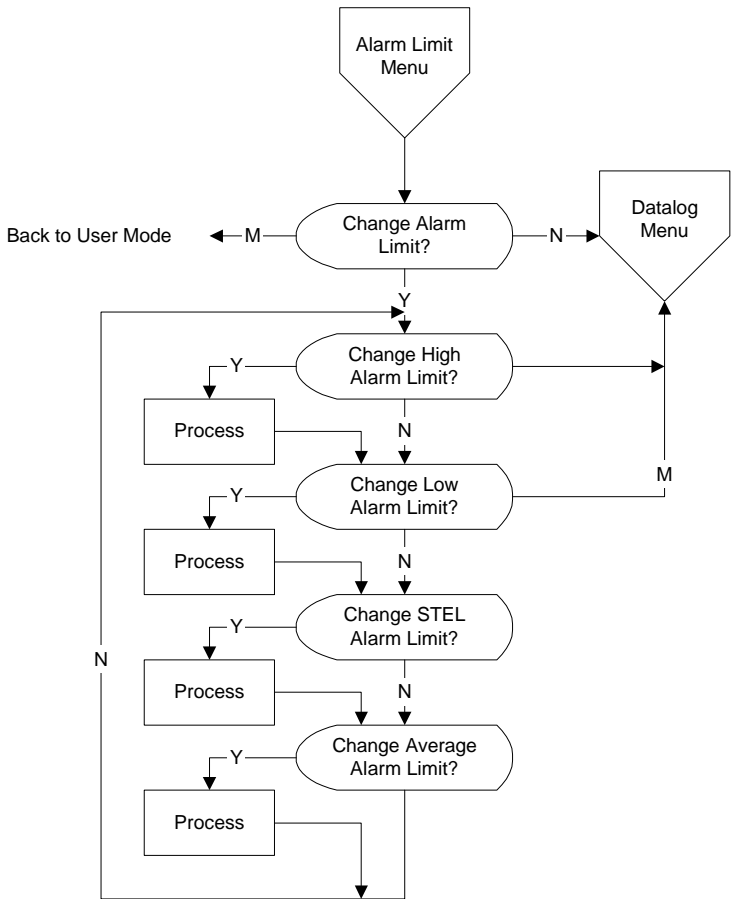

## Programming Menu: Datalog Menu

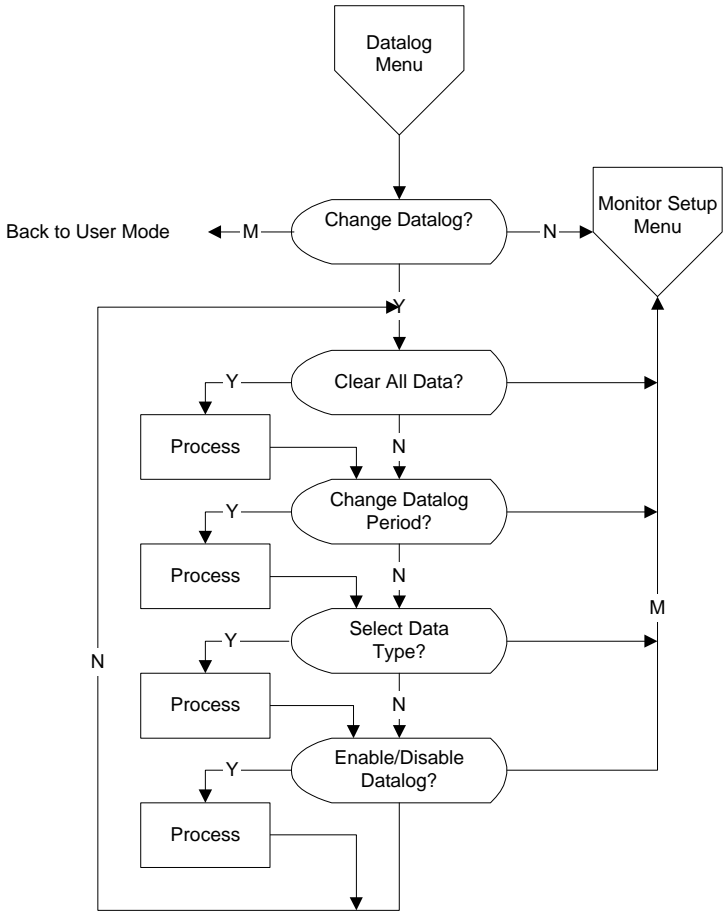

# Programming Menu: Monitor Setup Menu

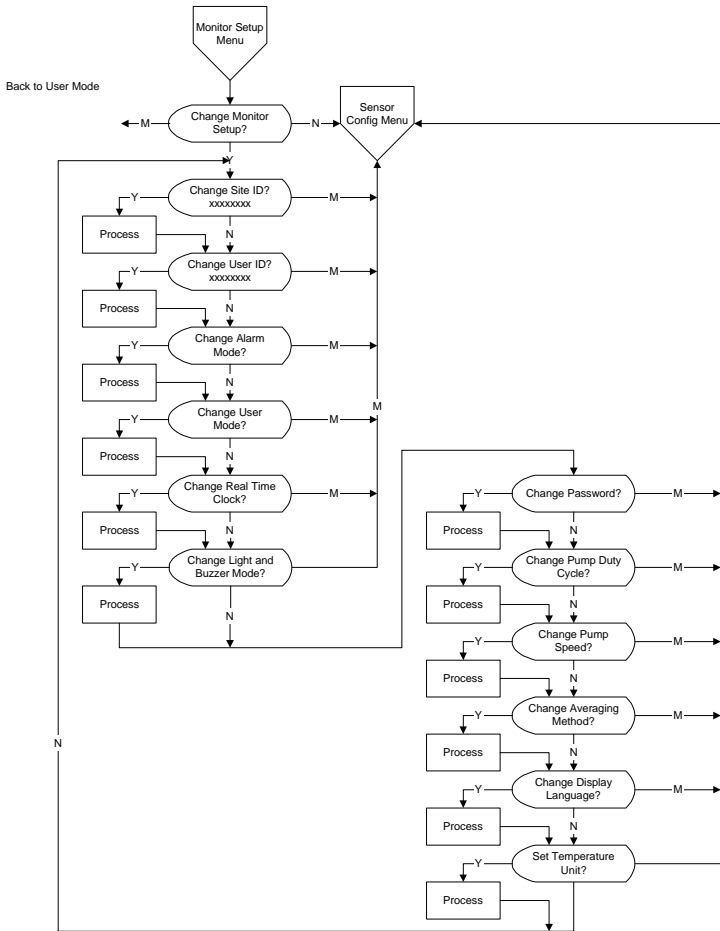

## Programming Menu: Sensor Configuration Menu

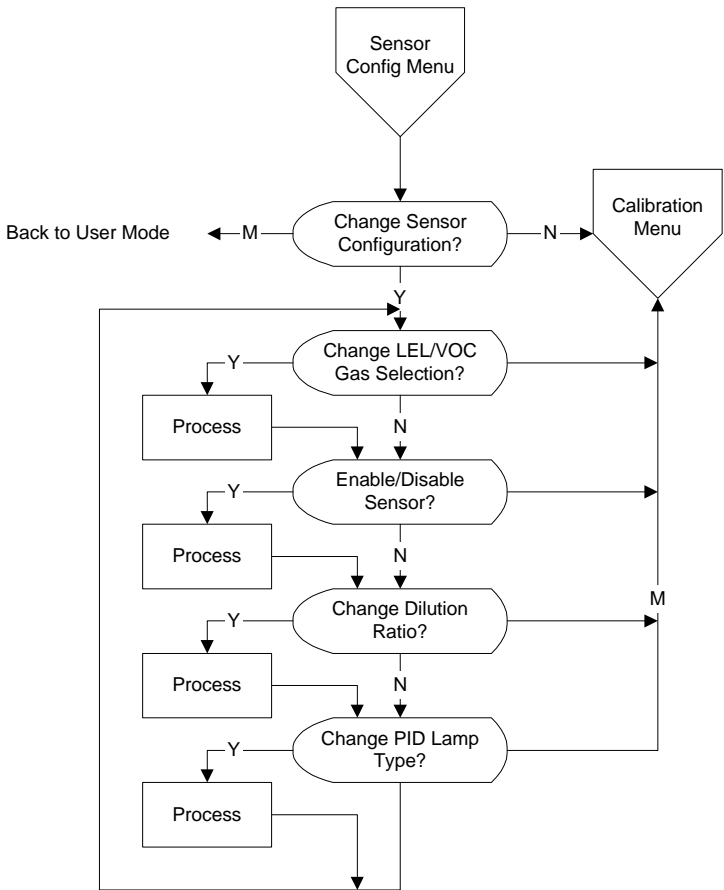

## Correction Factors

Correction factors for a number of commonly used compounds for the LEL sensor, 10.6 eV and 11.7 eV PID sensors has been provided. A comprehensive list of correction factors is available at the RAE website [www.raesystems.com](http://www.raesystems.com), under Technical Note 106 and Technical Note 156.

VOC correction factors are measured relative to isobutylene gas and LEL correction factors are measured relative to methane gas. All gases are measured at less than 5% relative humidity and 25°C. These factors may change at higher concentration levels, different temperatures and/or humidity conditions. The SentryRAE uses the preset table below in the non-volatile memory to calculate and display the correct gas reading. Make sure the name of the measurement gas and calibration gas are entered correctly. (See Section 4.4.6 Change LEL/VOC Span Gas and Section 4.8.1 Correction Factors.) If the correction factor of the gas is <1.0, it implies that the sensitivity to the gas is higher than that of isobutylene (VOC) or methane (LEL).

<b>Compound</b>	<b>10.6 eV</b>	<b>11.7 eV</b>	<b>LEL</b>
Acetaldehyde	6	3.3	1.8
Acetic acid	22	2.6	3.4
Acetone	1.1	1.4	2.2
Acrylic acid	12	2.0	
Acrylonitrile	NR	1.2	
Allyl alcohol	2.4	1.7	
Ammonia	9.7	5.7	0.8
Benzene	0.53	0.6	2.2
Butadiene	0.85	1.1	2.5
Butane, n-	67	1.2	2.0
Butyl acetate, n-	2.6		
Butyl acrylate, n-	1.6	0.6	
Carbon disulfide	1.2	0.44	
Carbon monoxide			1.2
Chlorine		1.0	

APPENDIX B

---

<b>Compound</b>	<b>10.6 eV</b>	<b>11.7 eV</b>	<b>LEL</b>
Cyclohexane	1.4	0.64	2.5
Cyclohexanone	0.9	0.7	
Dichloroethane, 1,2-	NR	0.6	1.5
Dichloroethene, t-1,2-	0.45	0.34	
Dichloromethane	NR	0.89	1.0
Diesel Fuel	0.7	0.4	
Diethylamine	1		
Dimethylhydrazine, 1,1-	0.8	0.8	
Epichlorohydrin	8.5	1.4	
Ethanol	12	8	1.7
Ethene	10	3	1.4
Ethyl acetate	4.6		2.2
Ethyl acrylate	2.4	1.0	
Ethyl benzene	0.52	0.51	2.8
Ethyl ether	1.1		2.3
Ethyl hexyl acrylate, 2-	1.1	0.5	
Ethyl sulfide	0.5		
Gasoline vapors	0.9		
Gasoline, whole	1.0	0.5	2.1
Heptane, n-	2.8	0.60	2.4
Hexamethyldisilazane	0.2	0.2	
Hexane, n-	4.3	0.54	2.3
Hydrazine	2.6	2.1	2.1
Hydrogen	NR	NR	1.1
Hydrogen sulfide	3.3	1.5	
Isobutane	100	1.2	1.8
Isobutene	1.00	1.00	1.5
Isobutyl acrylate	1.5	0.60	
Isopropanol	6.0	2.7	2.6
Jet fuel JP-4	1.0	0.4	3.4
Jet fuel JP-5	0.6	0.5	3.4
Jet fuel JP-8	0.6	0.3	3.4

APPENDIX B

---

<b>Compound</b>	<b>10.6 eV</b>	<b>11.7 eV</b>	<b>LEL</b>
Methane	NR	NR	1.0
Methanol	NR	2.5	1.5
Methyl acrylate	3.7	1.2	
Methyl ethyl ketone	0.9	1.1	2.6
Methyl isobutyl ketone	0.8	0.6	
Methyl methacrylate	1.5	1.2	
Methyl t-butyl ether	0.9		
Nitric oxide	5.2	2.8	
Octane, n-	1.8		2.9
Pentane	8.4	0.7	2.2
Perchloroethene	0.57	0.31	
Pinene, $\alpha$	0.31	0.47	
Pinene, $\beta$	0.37	0.37	
Propane	NR	1.8	1.6
Propene	1.4	1.6	1.5
Styrene	0.40	0.4	
Tetrahydrofuran	1.7	1.0	
Toluene	0.50	0.51	2.6
Trichloroethane, 1,1,1-	NR	1	
Trichloroethene	0.54	0.43	
Vinyl chloride	2.0	0.6	1.5
Xylene, m-	0.43	0.40	2.7
Xylene, o-	0.59	0.69	3.0
Xylene, p-	0.45	0.62	2.8





---

## **RAE Systems, Inc. Main Office**

1339 Moffett Park Drive  
Sunnyvale, California 94089, USA

### **Contact Numbers**

Fax

408.752.0724

Telephone

408.752.0723

Instrument Sales

877.RAE.CUSTOMER

(877.723.2878)

Tubes Sales

888.RAE.TUBE

(888.723.8823)

Technical Support

888.723.4800

### **E-mail**

[RaeSales@raesystems.com](mailto:RaeSales@raesystems.com)

[Tech@raesystems.com](mailto:Tech@raesystems.com)

### **Website**

[www.raesystems.com](http://www.raesystems.com)

**Important Note:** Before returning the unit for service or repair, please obtain a Return Material Authorization (RMA) Number for proper tracking of your equipment. Packages without RMA Numbers will be refused at the factory.

---