

# Model 711/71

Total Suspended Solids  
Interface Level Analyzer  
Operator's Manual

<b>General Information .....</b>	<b>3</b>
Product Description.....	3
<b>OPERATION IN THE GRAMS PER LITER MODE.....</b>	<b>4</b>
START-UP .....	4
<b>CALIBRATION .....</b>	<b>4</b>
ZERO .....	4
SAMPLE AND SPAN .....	5
MEASURING .....	7
<b>OPERATION IN THE LEVEL MODE .....</b>	<b>8</b>
CALIBRATION .....	8
MEASURING .....	9
ERROR CODES .....	9
AUTOMATIC SHUTOFF .....	10
<b>BATTERY REPLACEMENT .....</b>	<b>11</b>
<b>SPECIAL FUNCTIONS.....</b>	<b>12</b>
CHANGING THE RESPONSE TIME OF THE G/L MODE .....	12
DISABLING THE AUTOMATIC SHUTOFF FEATURE .....	12
SENSOR TEST MODE .....	12
FACTORY DEFAULT SPAN CALIBRATION.....	12
<b>GUARANTEE AND REPAIR POLICY.....</b>	<b>13</b>

## General Information

---

### Product Description

The Model 711 Meter with Model 71 sensor is a handheld microprocessor based digital instrument for the measurement of suspended solids in wastewater. The unit has two independent modes of operation that make it useful in performing two distinct tasks in a typical wastewater treatment facility. When the unit is operated in its "grams per liter" mode, the Model 711 is a stable and accurate meter for the measurement of suspended solids in the range normally found in aeration basins (typically 500 to 5000 mg/l). When the unit is operated in its "level" mode, it becomes a fast responding indicator of relative solids concentrations that is ideal for locating the blanket interface level in clarifiers. The two modes of operation are calibrated independently, truly making the unit function as two instruments in one.

The Model 71 sensor is an extremely rugged unit built of casted epoxy. The sensor works on the principle of single gap light absorption. A temperature compensated bright red LED provides an extremely stable and accurate light source. The receiver consists of a precision array of silicon photodiodes that are also temperature compensated. The meter measures the percentage of light absorbed across the 1/4" sensing gap and converts this information to a suspended solids reading using carefully verified digital linearization techniques. The streamlined exterior shape and V-grooved sensing gap of the Model 71 insure that the sensor may be lowered into thick process liquids without trapping excess particles in the sensing gap or disturbing an interface to be measured. The sensor cable features a tough polyurethane jacket, and has an internal Kevlar strand to provide maximum strain relief under tension. The cable is marked with white bands at intervals of 1 foot, with red bands at 5-foot intervals for quick estimation of the depth of immersion of the sensor.

The meter is housed in a rugged waterproof enclosure of glass-reinforced nylon. It is designed for operation over the range of -20 to 60 degrees Celsius. The unit is powered by a single standard 9VDC alkaline battery.

## OPERATION IN THE GRAMS PER LITER MODE

---

### START-UP

The Model 711 is supplied with a fresh battery installed. To begin operation, all that is necessary is to plug the sensor into the connector marked **SENSOR** and press the **ON** button. The meter always begins operation in the grams per liter mode. This is indicated by a segment on the LCD display that points to the "g/l" legend on the right side of the display. Before using the system for the first time, the system should be zeroed and spanned.

### CALIBRATION

---

The electronic and optical components for the Model 711/71 system are quite stable, so recalibration schedules will be dictated mainly by process changes. The zero point should only drift as a result of scratches developing on the optical faces within the sensor gap. Therefore, the system should be zeroed when new, with subsequent rezeroing only necessary every six months or so. The system will need to be respanned only as significant changes occur in the size and type of particles in the process being measured. Under normal conditions, this will be a seasonal type of change, so calibration every month will be sufficient to account for these changes. Each plant will be different, so it is really up to the user to determine, over time, a recalibration schedule that will provide a comfortable degree of accuracy.

### ZERO

Zeroing the sensor is a simple one button operation on the Model 711. For best accuracy, zeroing should be performed indoors or out of direct sunlight. The sensor should be clean. The procedure is as follows:

1. Place the Model 71 sensor in a container of clean (potable) water. Never use plant water for this procedure.
2. Be sure that the Model 711 is in the g/l mode by checking the indicator on the display.
3. Press the ZERO button.
4. For the next ten seconds, the CAL indication segment will light, and the display should show a moving bar that crosses the screen about once per second. When the unit has finished its sampling process, it will average the readings taken over this time and store the result as the zero point. The unit will then jump back into the normal "g/l" measurement mode automatically. The sensor may then be removed from the clean water.

NOTE: Zeroing the analyzer with the sensor held in air will **NOT** provide an accurate zero point. Air DOES NOT transmit as much light across the sensor gap as water.

## **SAMPLE AND SPAN**

Any optically based device for measuring suspended solids should only be span calibrated against a typical sample of the actual process water being measured. Synthetic laboratory standards will add unnecessary inaccuracies to the system and are not recommended. The Model 711 utilizes its microprocessor memory in a unique way to make span calibration as easy and accurate as possible. This calibration is performed as a two-step process. First, the SAMPLING function of the meter is used to store actual process conditions to the instrument's memory. Later, when standard laboratory analysis results are available for those previous conditions, the meter's SPAN function will recall the stored value and allow the user to adjust the span value accordingly. The procedure, in detail, is as follows:

1. The Model 711 meter should be taken to an aeration basin (or whatever aqueous process) that will normally be measured.
2. Turn the unit on and verify that the unit is in the "g/l" mode as indicated by the display segment.
3. Immerse the sensor in the process to a depth of two to three feet.
4. Press the SAMP button. For the next ten seconds, the CAL indication segment will light, and the display should show a moving bar that crosses the screen about once per second. When the unit has finished its sampling process, it will average the readings taken over this time and store the result in its memory as a basis for a future span calibration. The unit will then jump back into the normal "g/l" measurement mode automatically. The sensor may then be removed from the water. (NOTE: At this point, you have NOT altered the calibration of the meter at all, you have only stored a value in memory for future use.)
5. At the same time as the above steps are performed, a physical sample of the process water should be taken from the same location. This sample should be analyzed using standard laboratory techniques to determine the suspended solids concentration.
6. While waiting for the above sample to be analyzed, NO special precautions are necessary to insure that the stored value is not lost. The meter may be used in either mode of operation, it may be turned on and off, and the battery may even be changed without affecting its memory. The value can only be rewritten by pressing the SAMP button again from the "g/l" mode.
7. Once the laboratory sample has been analyzed, again turn on the meter and verify that it is in the "g/l" mode. The sensor need not be in water.
8. Press the SPAN button. The CAL segment of the display will light, and the meter will immediately read the suspended solids concentration value that was detected at the time the SAMP button was last pressed.

9. Use the up and down arrow keys to change this value to agree with the laboratory analysis.
10. Press the SPAN key again to enter this new calibration value. The new span value will be stored to memory and the meter will jump back into the standard "g/l" measurement mode. It is now ready to use.

## MEASURING

Once the system is calibrated, operation in the grams per liter measurement mode is simply a matter of turning on the meter and submerging the sensor in the process. If the meter is already turned on, but is in the LEVEL mode, press the G/L\_LEVEL key to switch the unit back to the g/l mode. For best accuracy, the following points should be kept in mind:

1. The system has a ten-second response time in the g/l mode of operation. This is absolutely necessary in the design to provide a stable reading. Suspended solid particles are not evenly distributed throughout any process, so the meter must take an average reading over time as the process moves through the sensor gap. Therefore, it is important to wait at least ten seconds after the sensor is in place before attempting to make a reading.
2. If the BAT segment of the LCD display is lighted, this means that the battery voltage has dropped to the point that the meter is operating at marginal levels. The battery should be replaced as soon as possible. If the battery voltage is allowed to drop further, the intensity of the light source in the sensor may drop enough to affect the meter's accuracy.
3. The location chosen for making readings within an aeration basin can affect the accuracy of the system. It is best to avoid an area where Return Activated Sludge is being added to the basin. Instead, choose an area that is more representative of conditions within the tank on an average.
4. Don't place the sensor within the center of an extremely turbulent column of rising air bubbles. Air bubbles, in very high concentrations, may affect the accuracy of the reading. Move the sensor to the side of one of these columns. (Fine bubble diffusers are not a problem.)

## OPERATION IN THE LEVEL MODE

---

The LEVEL mode of operation of the Model 711 is intended to be used in clarifiers or settling tanks as a quick and convenient method of locating interfaces to settled blankets in these tanks. In this mode of operation, the meter responds very quickly, but less accurately, to changes in suspended solids concentrations. A zero and span function that is completely independent of the grams per liter mode is used to adjust the meter to a 0 to 100% scale. In this scale, 0 represents the concentration of solids at the top or clear part of the tank, while 100 indicates the concentration of solids at the bottom, or thickest, part of the tank. When the sensor is slowly lowered into the tank, the point at which the reading changes significantly can be easily determined. By observing the cable markings, the depth of the interface is known.

### CALIBRATION

Calibrating the Model 711 to work in the LEVEL mode is a quick and easy single button zero and span process. Since the calibration is not critical for the determination of interface levels, the calibration steps need rarely be performed as long as the system is used in similar tanks. If the unit will be used in both primary and secondary clarifiers, however, the operator may find it convenient to change the calibration each time he moves to a new type of tank. **Keep in mind that changing the zero and span of the Model 711 in the LEVEL mode has absolutely no effect upon its calibration values in the grams per liter mode.**

The calibration procedure is as follows:

1. Turn on the unit and press the G/L\_LEVEL key once to switch the unit to the LEVEL mode of operation. The segment of the LCD display next to the LEV legend should light. The level mode of operation is also distinguished by the lack of a decimal point in the reading.
2. Lower the sensor into the clarifier until it is just below the surface in relatively clean water.
3. Press the ZERO key. For the next ten seconds, the CAL indication segment will light, and the display should show a moving bar that crosses the screen about once per second. When the unit has finished its sampling process, it will average the readings taken over this time and store the result as the zero point. The unit will then jump back into the normal LEV mode automatically.
4. Lower the sensor to the bottom of the tank where solids are the thickest.

5. Press the SPAN key. For the next ten seconds, the CAL indication segment will light, and the display should show a moving bar that crosses the screen about once per second. When the unit has finished its sampling process, it will average the readings taken over this time and store the result as the 100% point. The unit will then jump back into the normal LEV mode automatically.
6. The meter is ready to use.

## MEASURING

Turn the unit on and place it in the LEV mode by pressing the G/L\_LEVEL key once. To avoid disturbing the blanket with the moving sensor, it is best to begin measurements with the sensor at the top of the tank. Lower the sensor slowly into the tank while observing the meter's display. The display will begin to increase noticeably at the point where the blanket interface begins. Usually, an increase of 10 counts indicates a significant increase in solids concentration.

The exact value at which an interface is declared is at the preference of the operator. If the depth of the very lightest layers are required, the interface may be declared at a reading of 15%. If only the thickest sludge layers are of interest, a value of 70% may be used as a benchmark. Each operator should make this decision based upon comparisons of their results with previously used methods and standards. Once the sensor is immersed to the point of the interface, the cable 1 foot incremental markings should be used to determine the depth of the interface.

## ERROR CODES

During operation, the Model 711 may determine that an error condition exists. If this happens, the LCD will display an error code in the form of "E *n*", where *n* is a number from 1 to 4. These 4 possible error codes have the following meanings:

- E 1** This error code indicates that the Model 711 is detecting no received light signal from the Model 71 sensor. This could be caused by any of the following conditions:
- \* The sensor is not properly connected to the meter.
  - \* The process into which the sensor was submerged is too thick (dark) to measure.
  - \* Faulty sensor or meter electronics.
- E 2** This error code will be displayed if the user presses the ZERO key while the unit is in the g/l mode but the sensor is not in clean water. Either the water or the sensor is too dirty to allow an accurate zero. Press any key to abort the zero process.
- E 3** This error code will be displayed if the user presses the SAMP key from the g/l mode but the sensor is submerged in water of nearly zero suspended solids concentration. The SAMPLE mode is intended to grab a value for span calibration, and the meter cannot be zeroed and spanned from the same value. Press any key to abort the sampling process.

**E 4** This error code will be displayed when the unit is first turned on if there is a problem with the meter's memory components. Call the factory for service information.

### **AUTOMATIC SHUTOFF**

As shipped from the factory, every Model 711 system has a feature that automatically turns off the power to the meter after 10 minutes with no new keypresses. This feature is intended to preserve battery life in cases where the meter is inadvertently left on. This feature can be disabled by the user as described in the section entitled SPECIAL FUNCTIONS.

## **BATTERY REPLACEMENT**

---

The Model 711 is supplied with a fresh battery. The low battery segment (BAT) will become visible when it is time to replace the battery. To replace the battery, follow the steps below:

1. Remove the 6 battery cover screws on the rear of the instrument.
2. Remove the battery and discard.
3. Snap a standard 9 VDC ALKALINE battery onto the connector and install in the battery compartment.
4. Reinstall the battery cover with its 6 screws, being careful that the waterproofing gasket is centered correctly and does not bind at any point.

## **SPECIAL FUNCTIONS**

---

The Model 711 meter has four special function modes that can only be activated as the meter is turned from off to on. The functions are activated by holding down one of the six upper keys while the ON key is pressed. These special functions are as follows:

### **CHANGING THE RESPONSE TIME OF THE G/L MODE**

As shipped from the factory, the meter has a response time of ten seconds (as described in the MEASURING section of the g/l mode in this manual). This provides a level of stability in the readings that should be appropriate for most applications. However, if the user would like to increase stability by adding response time, holding down the up arrow key as power is turned on to the meter will change the response time to 15 seconds. This change will remain in effect if the meter is turned on and off normally. If the user desires to return the meter to its original 10 second response time, he should hold the down arrow key as he turns on the power to the meter.

### **DISABLING THE AUTOMATIC SHUTOFF FEATURE**

Normally, the Model 711 will turn itself off automatically 10 minutes after the last keypress. It is possible to disable this feature by holding down the SAMP key as power is turned on to the meter. This change will remain in effect if the unit is turned on and off normally. If the user would like to reactivate the automatic shutdown feature, he should hold down the g/l\_LEVEL key as power is turned on to the meter.

### **SENSOR TEST MODE**

If the ZERO key is held as the power is turned on to the meter, the meter will begin operating in a special sensor test mode that may be used to aid in troubleshooting. In this mode, the display will read a number from 1 to 999 that indicates the raw intensity of light that is striking the receiver circuit within the sensor. A good sensor will produce a value of 80 to 400 when it is held in air. The intensity drops as the light is blocked. If you call the factory for assistance in solving a problem, you may be asked to place the unit in this mode of operation as a means of helping the factory technician troubleshoot your problem.

### **FACTORY DEFAULT SPAN CALIBRATION**

If the SPAN key is held as power is turned on to the meter, the meter will replace its grams per liter span calibration values with the factory default values. This may be useful when using the system in a new application where no calibration equipment is available. If the meter has been properly zeroed in clean water, the meter will read values that are in the ballpark for an average waste treatment plant aeration basin. No absolute accuracy is guaranteed after this procedure, but the numbers will, in the least, be useful for observing trends in the solids concentration over time.

## **GUARANTEE AND REPAIR POLICY**

---

The Royce Model 711 meter and Model 71 sensor are guaranteed for 1 year against defective materials and workmanship. They will be replaced or repaired free of charge during the guarantee period. Freight to our factory to be paid by the customer.

All shipments are insured. If you receive a damaged unit, please notify Royce Instrument Corp. so that we may authorize return of the equipment. Shipments to Royce should be protected and insured by the customer.

Repairs to the equipment not covered by the guarantee will be billed per standard service charges. Please contact the factory service department for pricing details. Royce may be contacted at 1-800-347-3505 for service information or technical assistance.

REVISIONS		DATE	APPROVED
ZONE	LTR	DESCRIPTION	

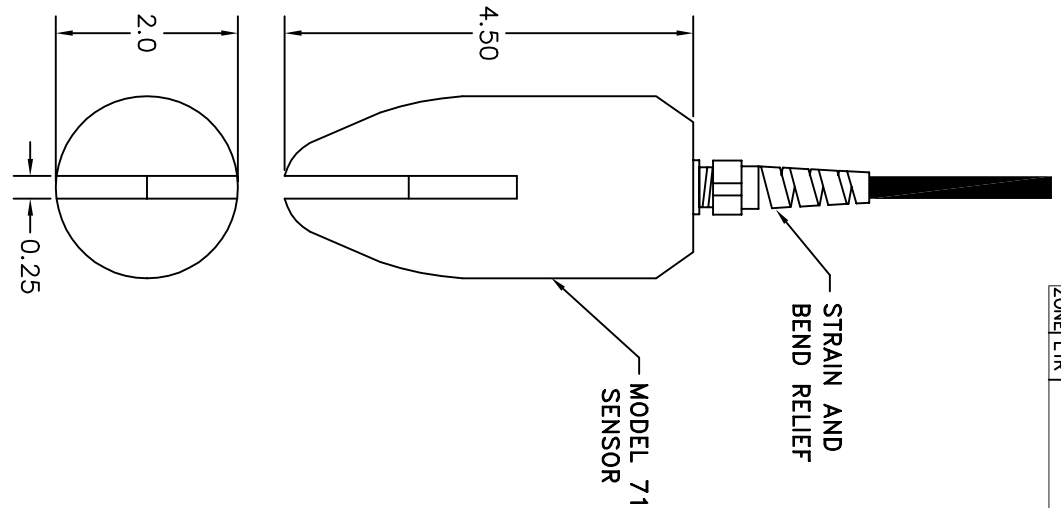
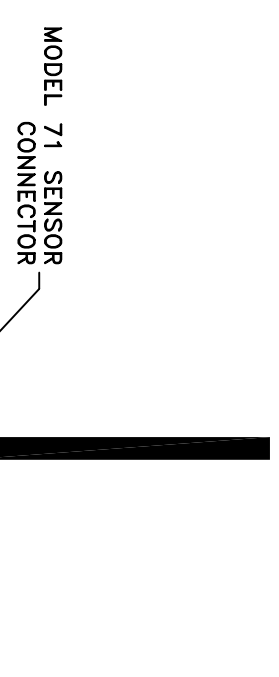

UNLESS OTHERWISE SPECIFIED: DIMENSIONS ARE IN INCHES TOLERANCES		CONTRACT NO.	
DECIMALS	ANGULAR	DRAWN	DATE
XX ±.010	X ±1°	D. BERLIN	5/2/95
XXX ±.005		CHECK	
DO NOT SCALE DRAWING		DESIGN	DATE
MATERIAL		M. DALFRÉS	5/2/95
FINISH	APPROVED	CUSTOMER	
	D. RADLE		5/2/95
SPEC.			
ROYCE TECHNOLOGIES-A UNIT OF SANITAIRE 13555 GENTILLY RD. NEW ORLEANS LA		TITLE	
		MODEL 711 TSS & BLD ANALYZER OUTLINE	
SIZE	DWG NO.	REV	
C	444N1000	-	
SCALE 1/1		SHEET 1 OF 1	