

# Sample Pro

Portable MicroPurge® Pumps PATENT PENDING 

# Sample Pro Portable MicroPurge Pump User's Guide

P/N 95181 REV. 1-24-03

*The World Leader in Air Powered Pumps*  
For Remediation, Landfills and Ground Water Sampling



*Ground water Sampling • Remediation, Leachate and Condensation Pumps • Floating Layer Recovery Systems • Air Strippers*  
QED ENVIRONMENTAL SYSTEMS

P.O. Box 3726 Ann Arbor, MI 48106-3726 USA • 1-800-624-2026 • FAX (734) 995-1170 • info@qedenv.com • www.qedenv.com  
1133 Seventh Street Oakland CA 94607-2601 • 1-800-537-1767 • FAX (510) 444-6789

COPYRIGHT© 2001 QED ENVIRONMENTAL SYSTEMS

COPYRIGHT© 2001 QED ENVIRONMENTAL SYSTEMS



<b>Topic</b>	<b>Page</b>
Introduction _____	1
Figure 1/Pump Overview _____	1
Description _____	2
Figure 2/Main Components _____	3
Assembly _____	4
Disassembly / Cleaning /Decontamination Note _____	5
Bladder Replacement _____	6
Figure 3/O-Ring Locations _____	10
Figure 4/ MP-SP-4C Assembly _____	11
Figure 5/ MP-SP-4P Assembly _____	12
Figure 6/ MP-SP-6C Assembly _____	13
Figure 7/ MP-SP-6P Assembly _____	14
Figure 8/ 38358 Tube Connector Assembly _____	15
Figure 9/ 38356 Tube Connector Assembly _____	16
Figure 10/ 38357 Tube Connector Assembly _____	17
Figure 11/ 38359 Tube Connector Assembly _____	18
Pump Kits _____	19
Specifications _____	20
QED Service Contacts _____	20
Important Warranty Note _____	20
QED Warranty _____	21

**Introduction**

The Portable MicroPurge® Pump, (Figure 1) is the first pump designed specifically to meet the needs of portable low-flow sampling: easy to adjust to low-flow purging rates and easy to decontaminate between sampling points. Decon is made easier by the pump having fewer parts, disassembly without tools, and quick-change, disposable bladders. The Portable MicroPurge Pump is compact, can pump from a tall 5-gallon bucket, and is offered with different tube connection sizes and methods. The pump is operated by compressed gas and a bladder pump control unit, and is ideally used with the MicroPurge **basics** models MP10 and MP15 controllers. The compressed gas is on the outside of the bladder and the pumped liquid is on the inside of the bladder, so there is no contact between the sample and the gas.

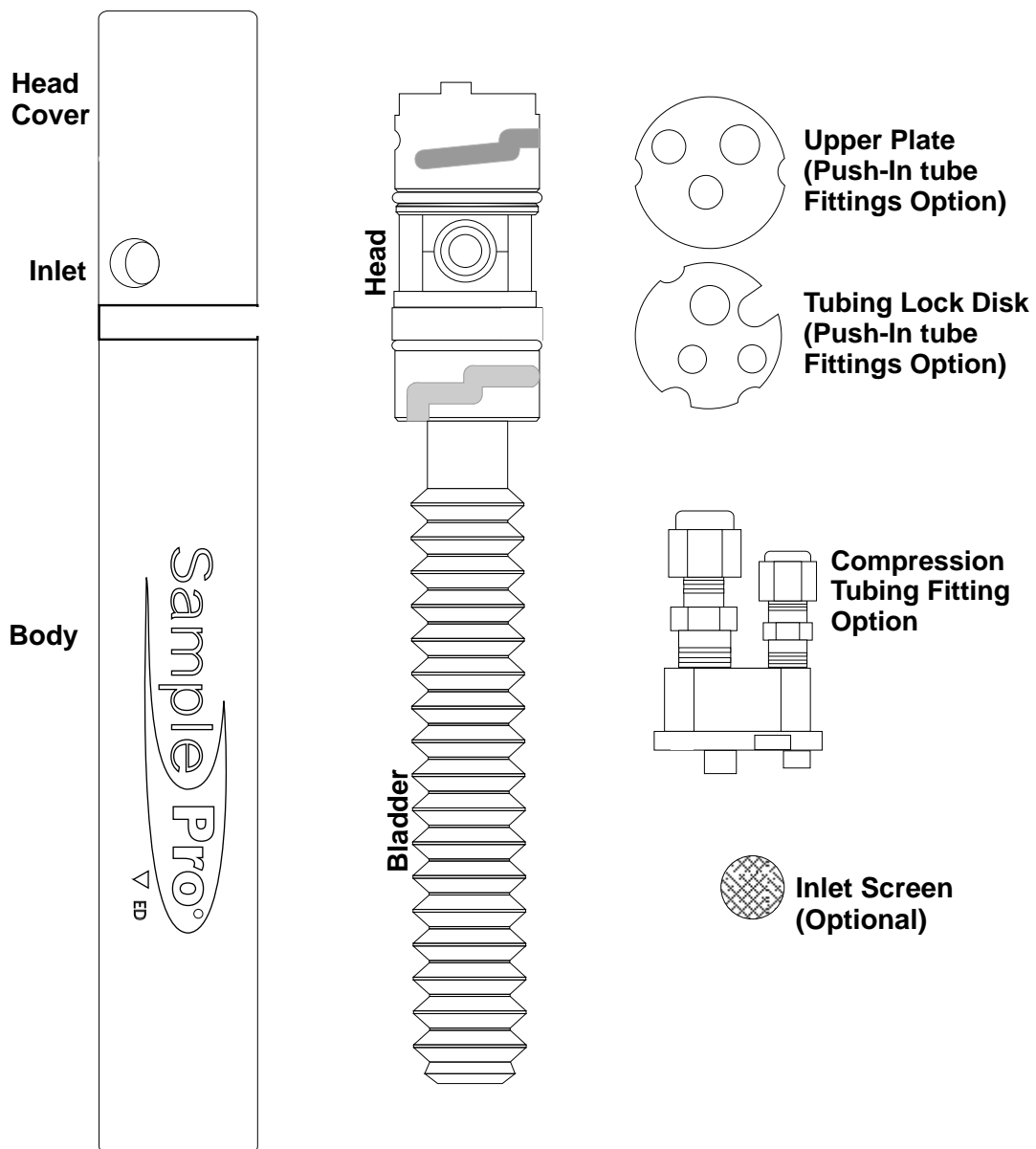

**Figure 1**

## Description

Figure 2 (Page 3) shows the main components of the Portable MicroPurge Pump and the assembled pump. The body twists off for quick change of the bladder, which is offered in polyethylene (PE) and optional teflon versions. The PE bladder provides a leak-tight seal for most applications without the use of clamps; a bladder collar is provided for seal assurance for pump submergences over 50 ft.

The cap of the pump twists off for full disassembly of the inlet and outlet check valves and the tubing connection components. Tubing connections are offered in two sizes in each of two types:

- Compression-type fittings for ¼" or 3/8" OD water discharge tube, and ¼" OD air supply tube.  
 Pump Models MP-SP-4C 1/4" O.D. water discharge  
 Pump Models MP-SP-6C 3/8" O.D. water discharge
- Push-in connections for ¼" or 3/8" OD water discharge tube, and ¼" OD air supply tube.  
 Pump Models MP-SP-4P 1/4" O.D. water discharge  
 Pump Models MP-SP-6P 3/8" O.D. water discharge

The push-in connection option is provided for greater ease of use in applications in which the tubing will be frequently changed. The push-in connections provide excellent pull out strength when used with QED tubing, so that use of a support cable is not required. However a connection eye is provided on the top of the push-in assembly for use of a cable when preferred. **The push-in and compression fittings on the SamplePro pump are designed to provide at least 100 lbs. pullout strength when used with QED tubing. QED is not responsible for loss of the pump if non-QED tubing is used.**

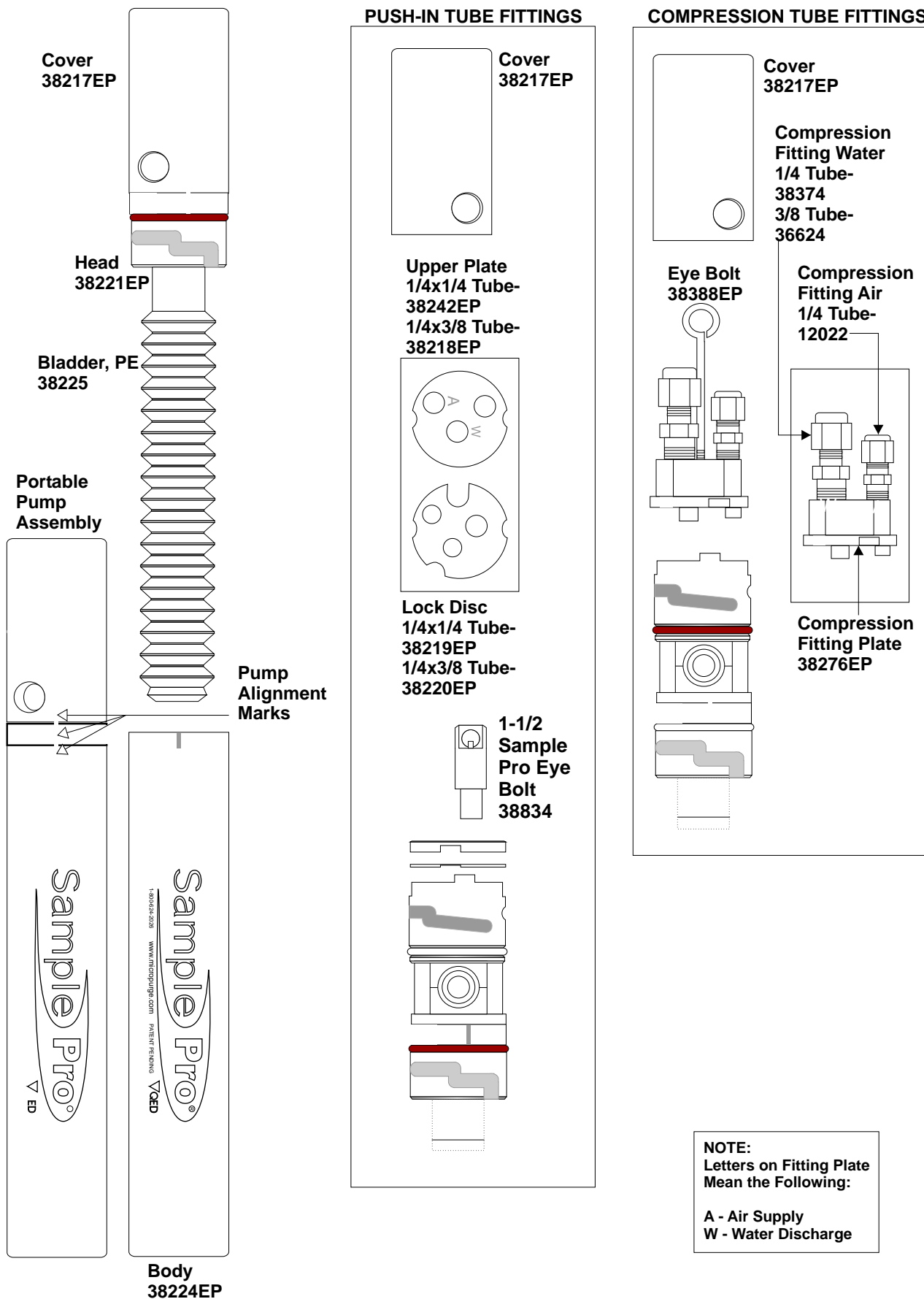

## Assembly

Use Figure 2, (Page 3) to identify main pump components and Figure 3, (Page 10) to identify O-ring locations. Full exploded drawings for each pump model are shown on pages 11 to 14; detailed exploded view drawings for each tubing connection configuration are shown on pages 15 to 18.

1. See figure 3 (page 10) to identify locations where O-rings are to be installed and install all O-rings.
2. Connect the bladder to the pump head. The PE bladder pushes onto the pump head barb until the bladder fully covers the barb. A clamping collar (white ring) is provided for pump submergences over 50 ft, to assure a leak tight seal of the bladder. Use the clamp collar by putting it over the pump head barb before pushing the bladder on, then pulling the collar back down firmly over the bladder and barb. The teflon bladder cartridge is installed by inserting the cartridge nipple into the center hole in the bottom of the pump head barb.
3. Attach the pump head to the body by engaging the bayonet dimples into the grooves and twisting them together until the engagement snap is felt and head and body alignment marks line up.
4. With the pump on its side, insert the inlet check ball (same as the discharge check ball) into the side of the pump head, then press in the inlet valve seat by pushing and twisting with your thumb.
5. With the pump vertical, insert the discharge check ball into the top of the pump head, then press in the discharge ball seat by pushing and twisting with your thumb.
6. For the push-in tubing fittings, place the thin metal lock disk in the "TOP" up position on the top of the pump head, with the lock disk edge slots lined up with the posts on the pump head. Then place the thick, upper plate on top of the lock disk, again with the slots and posts lined up. Finally, twist the pump cap onto the pump head until the engagement snap is felt and the hole in the side of the pump cap lines up with the inlet port. Cover and body alignment marks will line up.
7. For the compression nut fittings, place the compression fitting plate onto the top of the pump head, with slots and posts lined up. The fitting nuts may need to be rotated or removed to allow the pump cap to be placed over the compression fitting assembly. Then twist the pump cap onto the pump head until the engagement snap is felt and the hole in the side of the pump cap lines up with the inlet port. Cover and body alignment marks will line up.

## Attaching Tubing

### Push-in Fittings

1. Following the previous assembly instructions, use a new lock plate and freshcut end of QED tubing to ensure proper pull-out strength of tubing connection. Re-use of the lock plate or old tube-end and/or use of other brands of tubing may significantly reduce pull-out strength and cause loss of pump in the well.
2. The upper plate is marked "W" for the water discharge tube and "A" for the air supply tube. With QED tubing, the air supply tube is shaded gray to distinguish it from the water discharge tube.
3. Insert each tube separately into the proper opening in the pump head, pushing firmly so that the tube penetrates beyond first resistance at least ½-inch into the pump. As a check on proper assembly, pull back on each tube to see that it is gripped securely.

## Compression Fittings

1. Insert tubing insert into I.D. of tubing (if required).
2. Insert tubing into fitting making sure that the tubing rests firmly on the shoulder of the fitting and that the nut is finger tight.
3. Tighten nut to secure tubing in fitting (approximately 1-1/4 turns beyond finger tight).

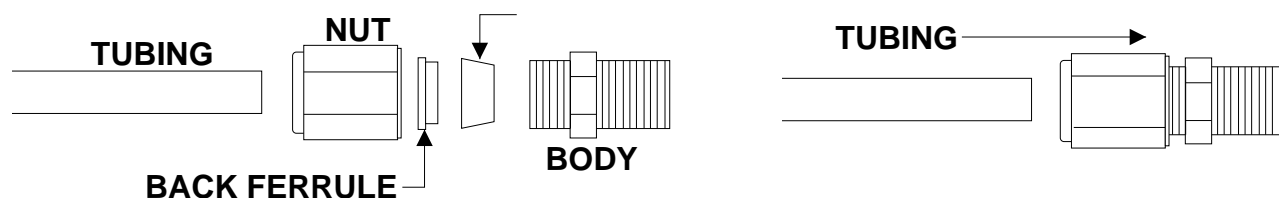

## Disassembly

Use Figure 2, (Page 3) to identify main pump components and Figure 3, (Page 10) to identify O-ring locations.

1. Reverse assembly sequence, taking care to position pump to retain check balls during removal of valve seats and stops. A coin or screwdriver can be used if necessary to remove the inlet valve seat and discharge check ball stop.
2. Pull the PE bladder off of the pump head barb by pulling firmly, then discard.

## Cleaning / Decontamination Note

If it is desired to operate the pump outside the well, such as in a pail for decontamination purposes, the operating pressure of the pump should be reduced to 35 PSI or less to avoid rupturing the bladder



### Standard Bladder Replacement

Connect the bladder to the pump head. The PE bladder pushes onto the pump head barb until the bladder fully covers the barb. A clamping collar (white ring) is provided for pump submergences over 50 ft, to assure a leak tight seal of the bladder. Use the clamp collar by putting it over the narrow, neck section of the bladder, slot side facing toward the pump head; then push the bladder neck fully onto the pump head barb by pushing on the bottom of the bladder, collapsing the bladder. After the bladder neck is in proper position, push the clamp collar up over the bladder and barb. The collar will seal the bladder sufficiently when moderate force (5-10 lbs) is used; excessive force will make later removal difficult.

**NOTE:** For reasons of contamination and leak integrity, these bladders are designed for one-time use only. QED cannot be held responsible for cross contamination or leakage failures if bladders are reused.

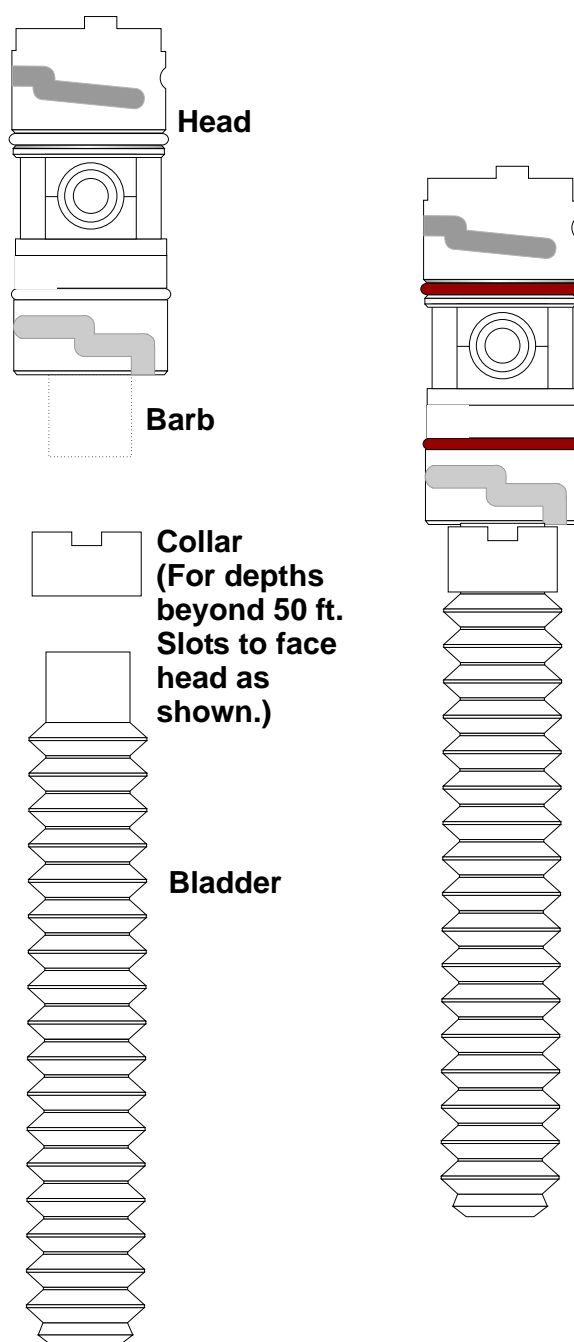

### Teflon Bladder Replacement

**WARNING:** Excessive drive gas pressures can damage the bladder. For normal operation, only 10-15 PSI over the pump depth (hydrostatic head, equivalent to .43 PSI per foot of depth) is sufficient to operate the pump. For pump depths over 200 ft (86 PSI hydrostatic head), it is recommended that initial pumping be performed with approximately 75 PSI drive gas pressure to move approximately 500 ml, equivalent to about 5 full bladder volumes, up into the discharge tubing to provide pumping resistance. Thereafter, full drive gas pressure can be applied. The drive gas pressure gauge on the **basics** controller is marked in both PSI and feet of hydrostatic head.

**NOTE:** For reasons of contamination and leak integrity, these bladders are designed for one-time use only. QED cannot be held responsible for cross contamination or leakage failures if bladders are reused.

1. Identify the components as shown below.

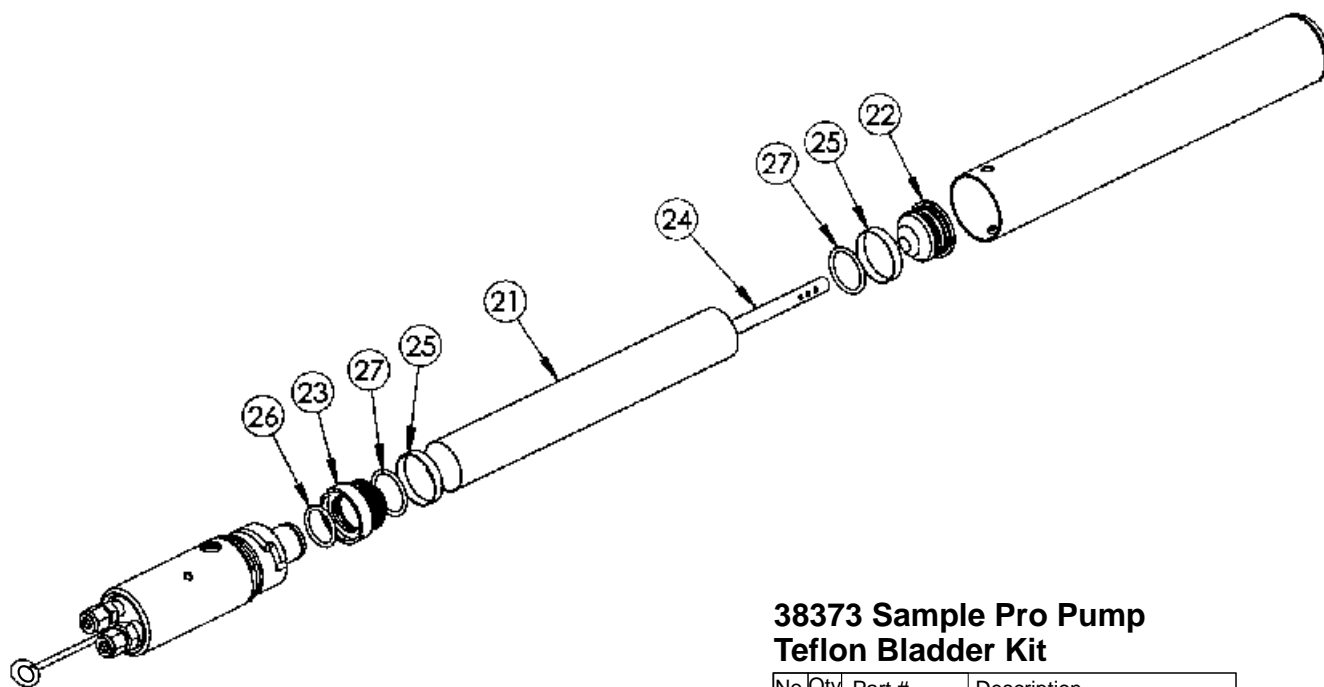

#### 38373 Sample Pro Pump Teflon Bladder Kit

No.	Qty	Part #	Description
21	1	38372	Teflon Bladder
22	1	38371EP	Bottom Spool
23	1	38370EP	Top Spool
24	1	38369EP	Dip Tube
25	2	38016	Clamp 030.2-505R S.S.
26	1	38378	O-Ring 2-118
27	2	38379	O-Ring 2-220

2. Change the teflon bladder by using the clamp tool to remove the bladder clamps.

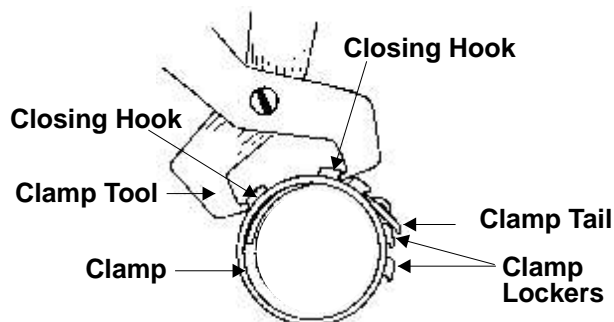

3. Pull apart the cartridge end pieces. Clean cartridge components as desired.

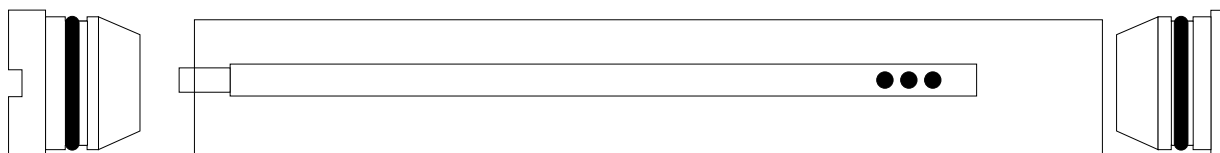

4. Install a new teflon bladder by placing the clamps loosely over the ends of the bladder, pushing the spool ends, with O-rings in place, onto each end of the center rod.

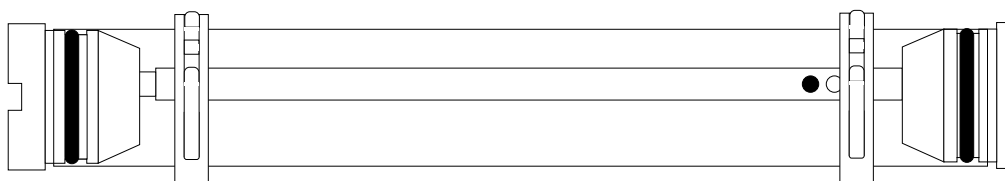

5. Position the clamps directly over the o-rings and then using the clamp tool, clamp the bladder into position onto the cartridge, as shown.

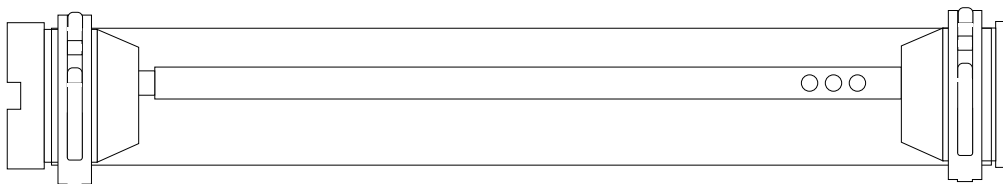

**NOTE:** Before clamping clamps down make sure the bladder is visible above the clamp all the way around the clamp.

6. Insert the outlet nipple from the upper spool piece into the center hole on the bottom of the pump head, as shown.

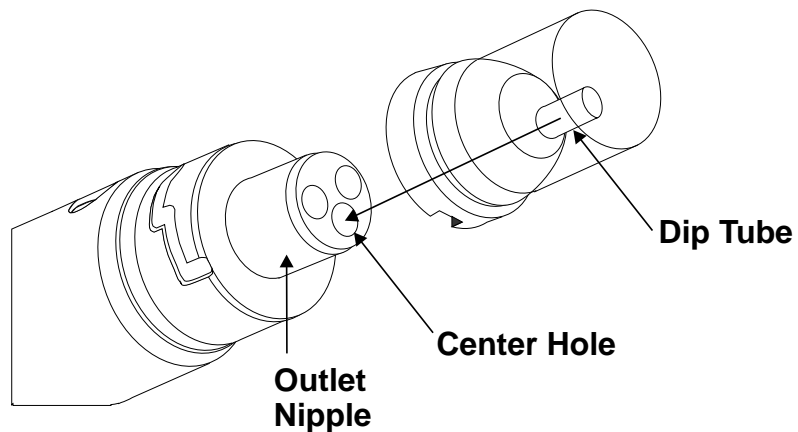

### O-ring Replacement

1. Inspect o-rings with each disassembly and replace as needed. Replacement of Top Spool, inner o-ring replacement shown below.

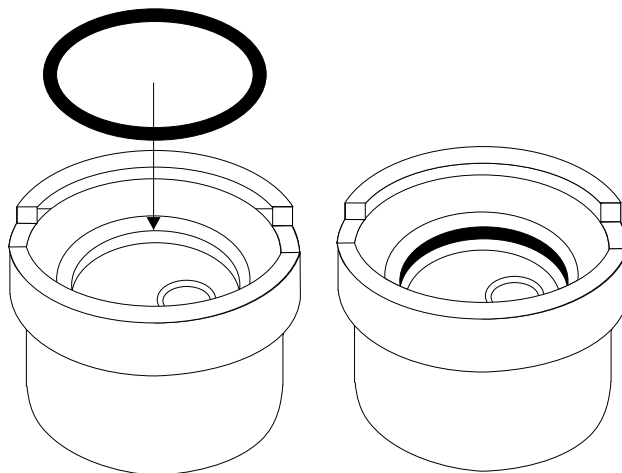

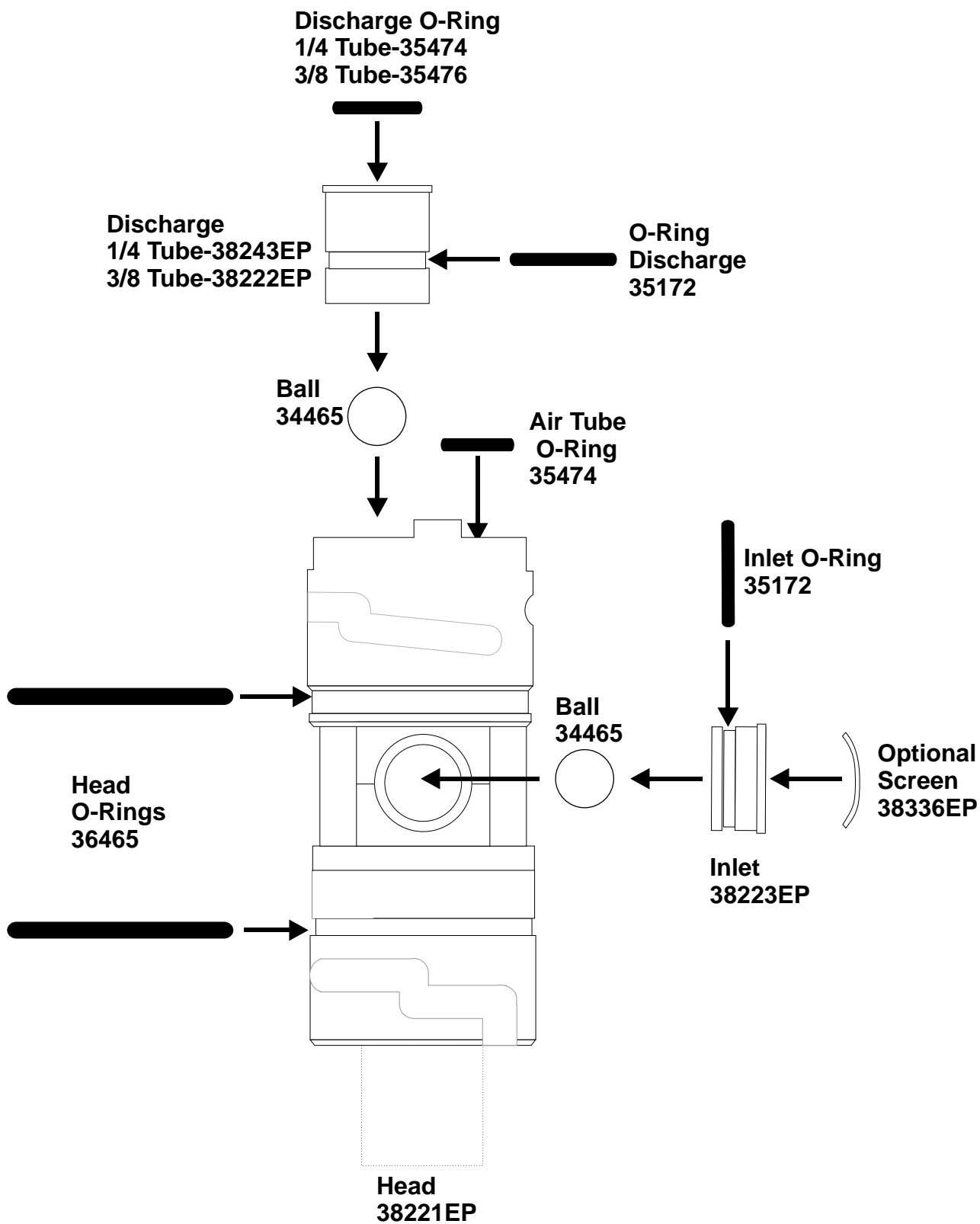

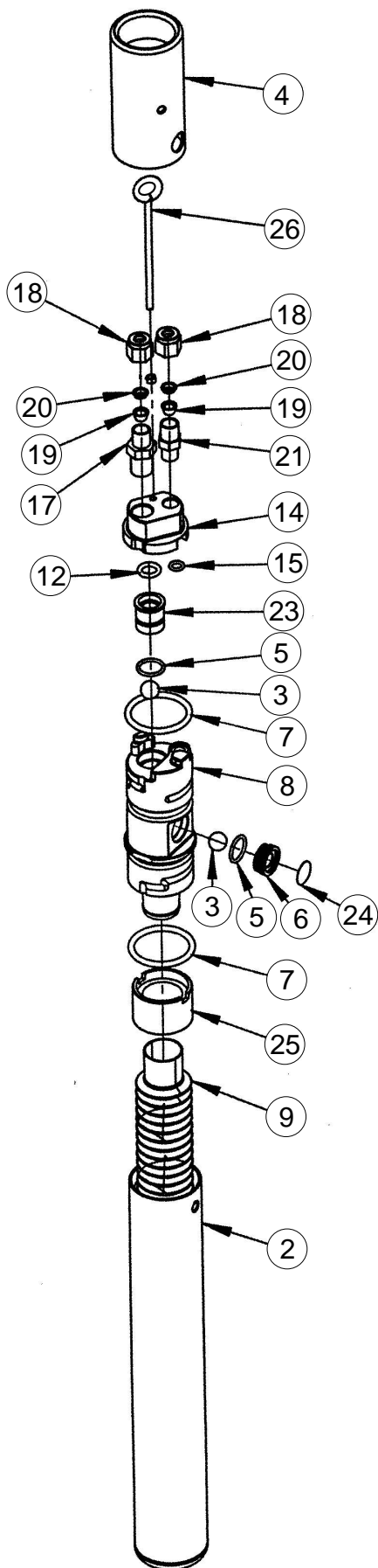

**MP-SP-4C SamplePro Pump Assembly**

No.	Qty	Part #	Description
2	1	38224EP	Body
3	2	34465	Ball Teflon 7/16 Dia.
4	1	38217EP	Cover
5	2	35172	O-Ring Viton 2-015
6	1	38223EP	Inlet
7	2	36465	O-Ring Viton 2-220
8	1	38221EP	Head
9	1	38225	Bladder PE
12	1	35476	O-Ring Viton 2-110
14	1	38267EP	Compression Fitting Plate
15	1	35474	O-Ring Viton 2-010
17	1	38374	Connector 1/4" T x 1/4" MPT SS
18	2	34954	Nut 1/4" T SS
19	2	34477	Ferrule 1/4" Lower SS
20	2	34476	Ferrule 1/4" Upper SS
21	1	12022	Connector 1/4" T x 1/8" MPT SS
23	1	38222EP	Discharge Tube 3/8"
24	1	38336	Inlet Screen
25	1	38340	Collar
26	1	38388EP	Eye Bolt with Nut

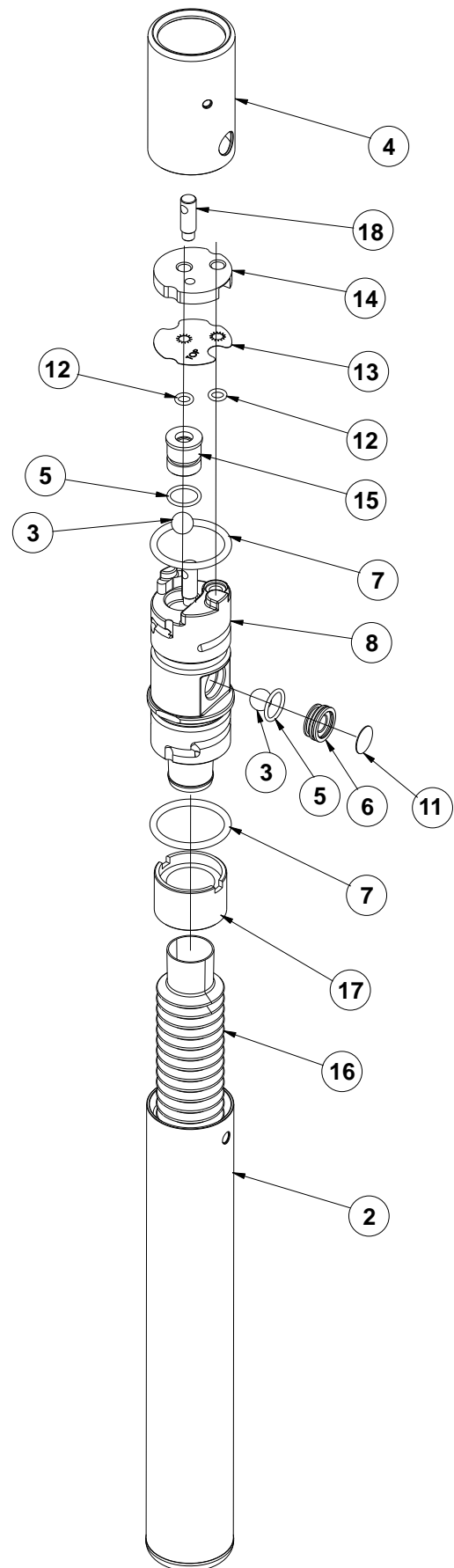

**MP-SP-4P SAMPLE PRO PUMP ASSY**

ITEM NO.	QTY.	PART NO.	DESCRIPTION
2	1	38224EP	BODY
3	2	34465	BALL TEFLON 7/16 DIA
4	1	38217EP	COVER
5	2	35172	O-RING VITON 2-015
6	1	38223EP	INLET
7	2	36465	O-RING VITON 2-220
8	1	38221EP	HEAD
11	1	38336	INLET SCREEN
12	2	35474	O-RING VITON 2-010
13	1	38219	GRATEPLATE 1/4" TUBE X 1/4" TUBE
14	1	38242EP	PLATE 1/4" TUBE X 1/4" TUBE
15	1	38243EP	DISCHARGE 1/4" TUBE
16	1	38225	BLADDER PE
17	1	38340	COLLAR
18	2	38834	1 1/2 SAMPLE PRO EYE BOLT

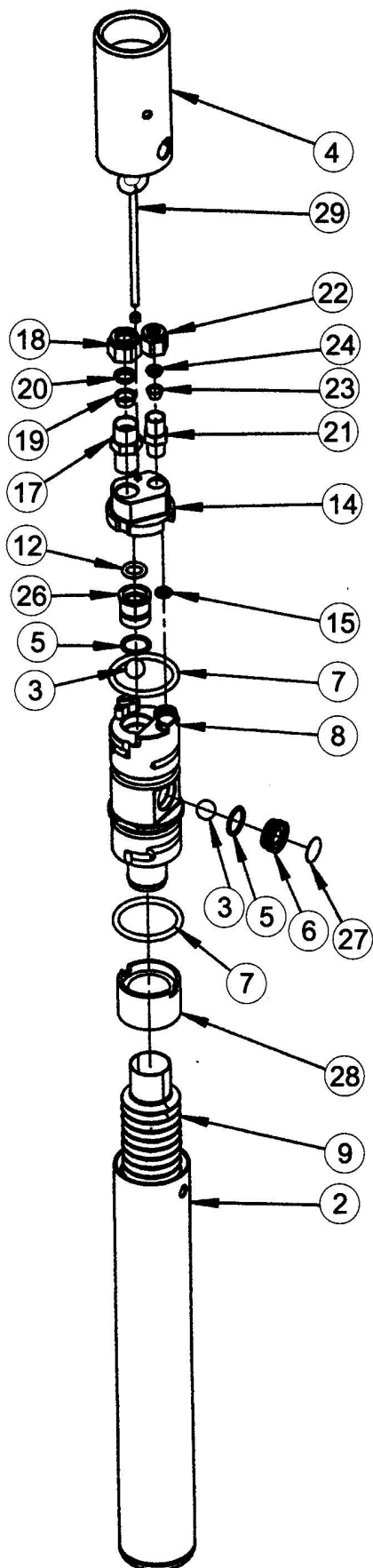

**MP-SP-6C SamplePro Pump Assembly**

No.	Qty	Part #	Description
2	1	38224EP	Body
3	2	34465	Ball Teflon 7/16 Dia.
4	1	38217EP	Cover
5	2	35172	O-Ring Viton 2-015
6	1	38223EP	Inlet
7	2	36465	O-Ring Viton 2-220
8	1	38221EP	Head
9	1	38225	Bladder PE
12	1	35476	O-Ring Viton 2-110
14	1	38267	Compression Fitting Plate
15	1	35474	O-Ring Viton 2-010
17	1	36624	Connector 3/8" T x 1/4" MPT SS
18	1	37984	Nut 3/8" T SS
19	1	34479	Ferrule 3/8" Lower SS
20	1	34478	Ferrule 3/8" Upper SS
21	1	12022	Connector 1/4" T x 1/8" MPT SS
22	1	34954	Nut 1/4" T SS
23	1	34477	Ferrule 1/4" Lower SS
24	1	34476	Ferrule 1/4" Upper SS
26	1	38222EP	Discharge Tube 3/8"
27	1	38336	Inlet Screen
28	1	38340	Collar
29	1	38388EP	Eye Bolt with Nut



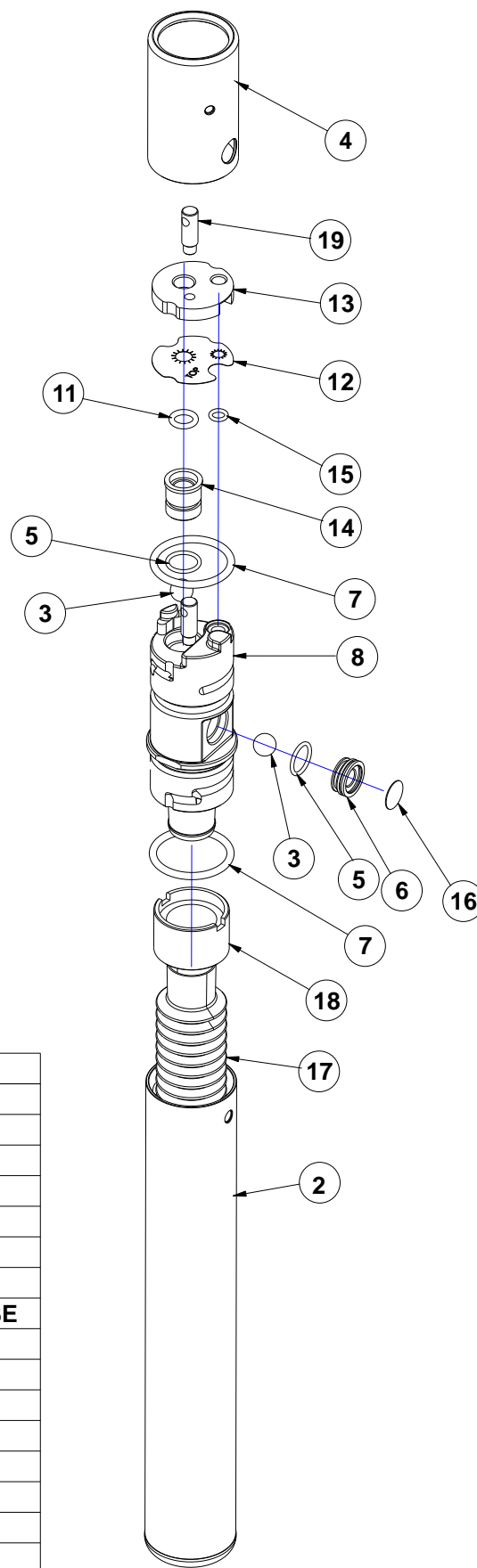

**MP-SP-6P SamplePro Pump Assembly**

ITEM NO.	QTY.	PART NO.	DESCRIPTION
2	1	38224EP	BODY
3	2	34465	BALL TEFLON 7/16 DIA
4	1	38217EP	COVER
5	2	35172	O-RING VITON 2-015
6	1	38223EP	INLET
7	2	36465	O-RING VITON 2-220
8	1	38221EP	HEAD
11	1	35476	O-RING VITON 2-110
12	1	38220	GRABEPLATE 1/4" TUBE X 3/8" TUBE
13	1	38218EP	PLATE 1/4" TUBE X 3/8" TUBE
14	1	38222EP	DISCHARGE 3/8" TUBE
15	1	35474	O-RING VITON 2-010
16	1	38336	INLET SCREEN
17	1	38225	BLADDER PE
18	1	38340	COLLAR
19	2	38834	1 1/2 SAMPLE PRO EYE BOLT

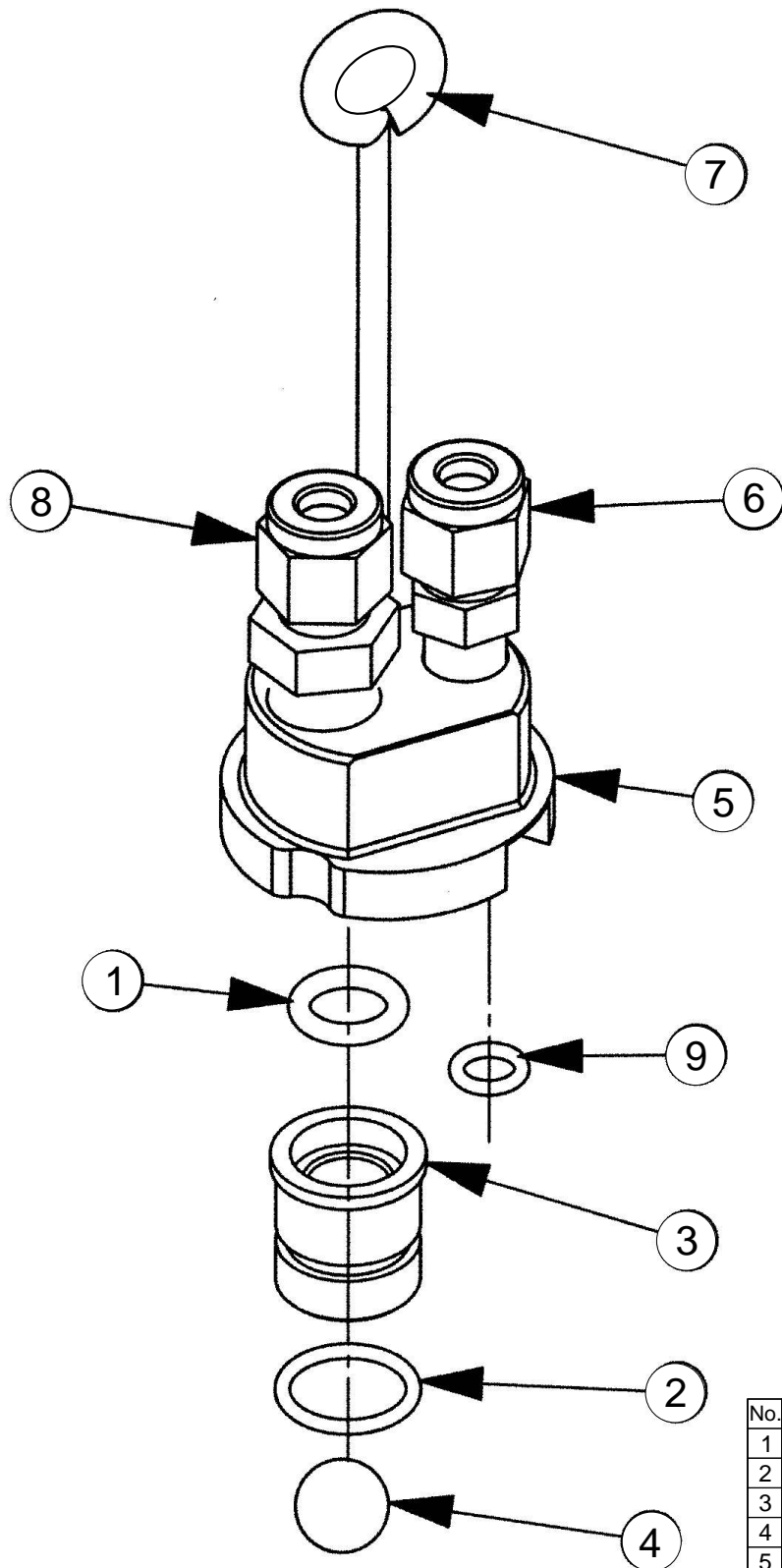

**38358 Tube Connector Assembly**  
 (For Use on MP-SP-4C)

No.	Qty	Part #	Description
1	1	35476	O-Ring Viton 2-110
2	1	35172	O-Ring Viton 2-015
3	1	38222EP	Discharge Tube 3/8"
4	1	34465	Ball Teflon 7/16 Dia.
5	1	38267EP	Compression Fitting Plate
6	1	35474	O-Ring Viton 2-010
7	1	38388EP	Eye Bolt with Nut
8	1	38374	Connector 1/4" T x 1/4" MPT SS
9	1	12022	Connector 1/4" T x 1/8" MPT SS

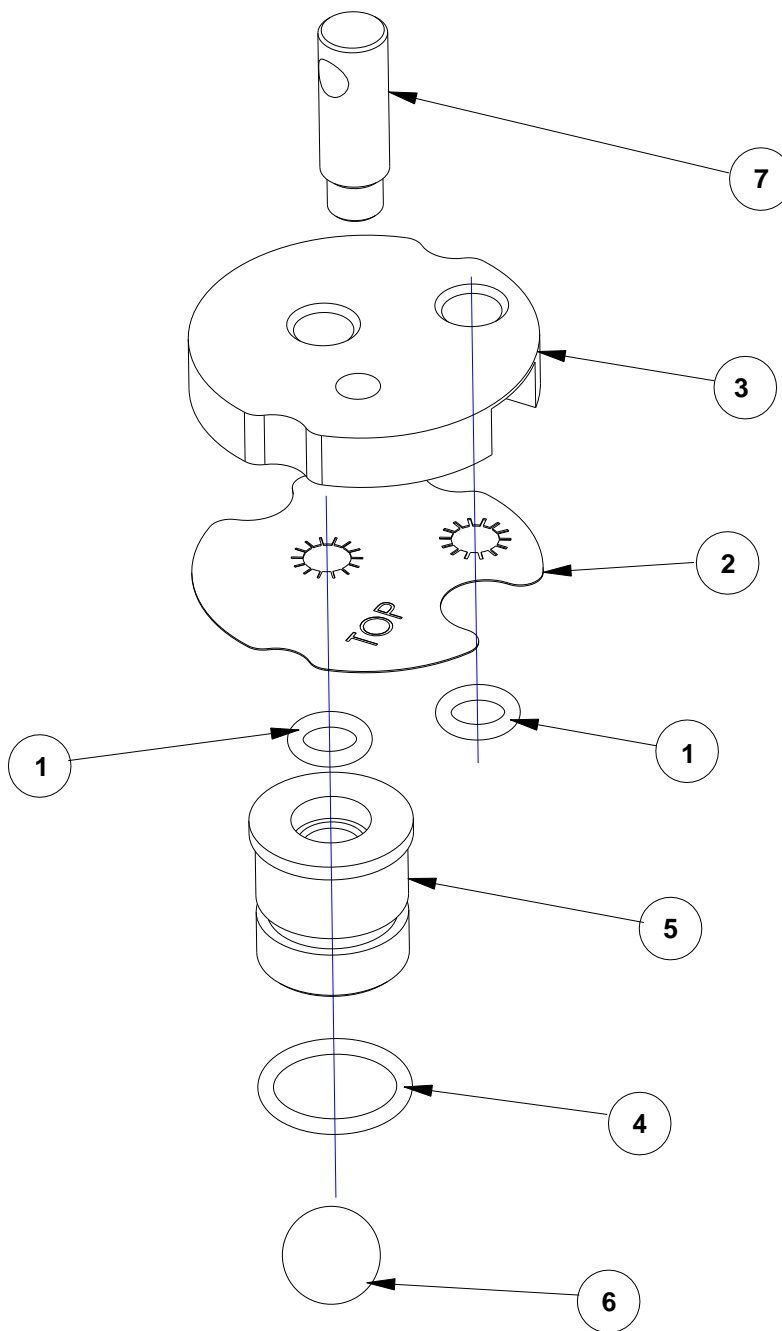

**38356 TUBE CONNECTOR PUSE ON MP-SP-4P**

ITEM NO.	QTY.	PART NO.	DESCRIPTION
1	2	35474	O-RING VITON 2-010
2	1	38219	GRABEPLATE 1/4" TUBE X 1/4" TUBE
3	1	38242EP	PLATE 1/4" TUBE X 1/4" TUBE
4	1	35172	O-RING VITON 2-015
5	1	38243EP	DISCHARGE 1/4" TUBE
6	1	34465	BALL TEFLON 7/16 DIA
7	1	38834	1 1/2 SAMPLE PRO EYE BOLT

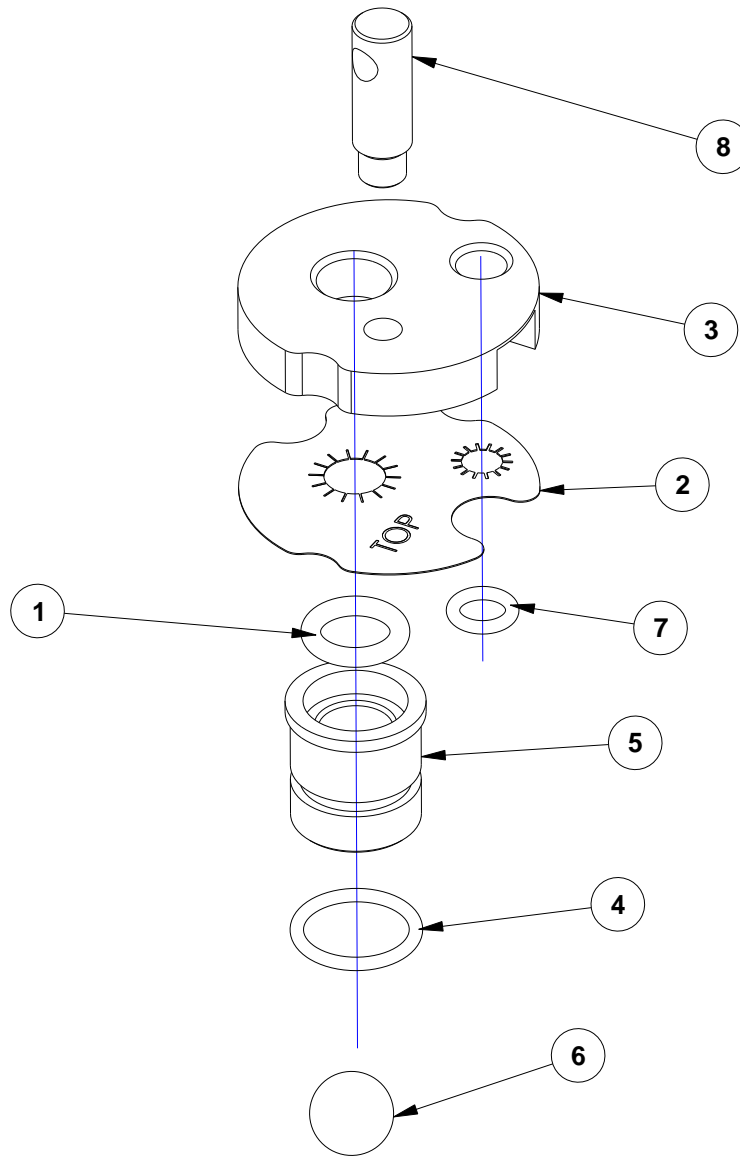

**38357 Tube Connector Assembly**  
 (For Use on MP-SP-6P)

ITEM NO.	QTY.	PART NO.	DESCRIPTION
1	1	35476	O-RING VITON 2-110
2	1	38220	GRABEPLATE 1/4" TUBE X 3/8" TUBE
3	1	38218EP	PLATE 1/4" TUBE X 3/8" TUBE
4	1	35172	O-RING VITON 2-015
5	1	38222EP	DISCHARGE 3/8" TUBE
6	1	34465	BALL TEFLON 7/16 DIA
7	1	35474	O-RING VITON 2-010
8	1	38834	1 1/2 SAMPLE PRO EYE BOLT

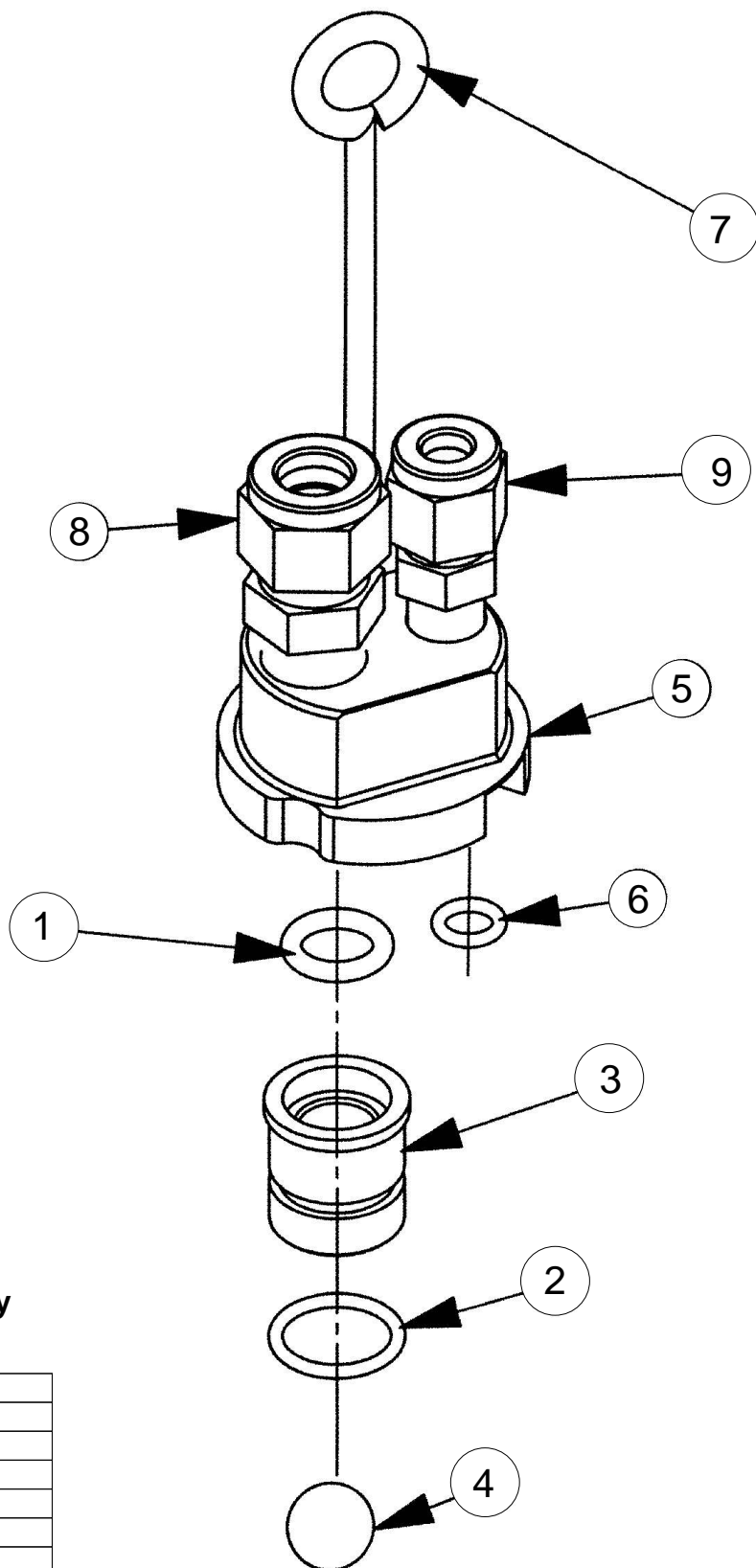

**38359 Tube Connector Assembly**  
 (For Use on MP-SP-6C)

No.	Qty	Part #	Description
1	1	35476	O-Ring Viton 2-110
2	1	35172	O-Ring Viton 2-015
3	1	38222EP	Discharge Tube 3/8"
4	1	34465	Ball Teflon 7/16 Dia.
5	1	38267EP	Compression Fitting Plate
6	1	35474	O-Ring Viton 2-010
7	1	38388	Eye Bolt with Nut
8	1	36624	Connector 3/8" T x 1/4" MPT SS
9	1	12022	Connector 1/4" T x 1/8" MPT SS

## SAMPLE PRO PUMP MODELS

**MP-SP-4P** Sample Pro Portable Pump push-in 1/4 x 1/4 tubing connector

**MP-SP-6P** Sample Pro Portable Pump push-in 1/4 x 3/8 tubing connector

**MP-SP-4C** Sample Pro Portable Pump compression 1/4 x 1/4 tubing connector

**MP-SP-6C** Sample Pro Portable Pump compression 1/4 x 3/8 tubing connector

## SAMPLE PRO PUMP KITS

**38355-** Portable pump (Base pump without any tubing connectors.)

**38356-** Tubing connector 1/4" x 1/4" tubing push-in

**38357-** Tubing connector 1/4" x 3/8" tubing push-in

**38358-** Tubing connector 1/4" x 1/4" tubing compression

**38359-** Tubing connector 1/4" x 3/8" tubing compression

**38360-** Bladder PE (10/pieces)

**38361-** Screen (10)

**38362-** O-ring complete pump (10 sets)

**38363-** O-ring head only(10 sets)

**38364-** Grab-plate for push-in connector 1/4" x 1/4" (10)

**38365-** Grad-plate for push-in connector 1/4" x 3/8" (10)

**38366-** Ferrules for compression connectors 1/4" x 1/4" tube (5 sets)

**38367-** Ferrules for compression connectors 1/4 x 3/8 (5 sets)

**38373-** Bladder Teflon cartridge (parts for optional Teflon bladder)

**38380-** Teflon replacement bladders (10) with clamps and O-rings

**38407-** Pump controller air fitting, connects to 1/4" air supply tubing

**38408-** Ball, Teflon 7/16" dia. (5) for inlet and outlet check valves

**38411-** Brushes Sample Pro (3 sizes, 2 of ea.)

**SPECIFICATIONS**

**Materials:**

**Body** - 303 stainless steel  
**Inlet & Discharge Housing** - 303 Stainless Steel  
**Bladder** - Polyethylene or Teflon®  
**O-rings** - Viton

**Dimensions:**

**Diameter** - 1.75" (44.5 mm)  
**Length** - 14.75" (37.5 cm) Push-in/16.5" (41.9 cm) Compression bottom of pump to centerline of inlet 12.12" (30.8 cm)  
**Weight** - 4.25 Lbs.(1.93 kg)

**Fittings:**

Stainless Steel Compression or Push-in Type  
**Air** - 1/4" (6.4 mm) O.D., 3/16" (4.7 mm) I.D.  
**Discharge** - 1/4" (6.4 mm) O.D., 3/16" (4.7 mm) I.D.  
**Discharge** - 3/8" (9.5 mm) O.D., 1/4" (6.4 mm) I.D.

**Maximum Lift:** 250 Feet (61 m)

**Flow Rates (1/4" (6.4 mm) x 1/4" (6.4 mm) O.D. Tubing)**

1.2 liters per min @ 25 ft. (7.6 m) (10 ft. (3 m) submergence)  
 400 ml per min. @ 150 ft. (45.6 m) (10 ft. (3 m) Submergence)

**Pump Volume:**

Milliliters	Liters	Ounces	Gallons
100	.100	3.34	.026

**For additional assistance contact QED Service at:**

**Phone:** 1-800-624-2026 1-734-995-2547  
**Fax:** 1-734-995-1170  
**E-mail:** [service@qedenv.com](mailto:service@qedenv.com)  
**24-Hour Service Hot Line:** 1-800-272-9559

**IMPORTANT WARRANTY NOTE**

***The push-in and compression fittings on the SamplePro pump are designed to provide at least 100 lbs. pullout strength when used with QED tubing. QED is not responsible for loss of the pump if non-QED tubing is used.***

QED ENVIRONMENTAL SYSTEMS, INC. ("Q.E.D.") warrants to the original purchaser of its products that, subject to the limitations and conditions provided below, the products, materials and/or workmanship shall reasonably conform to descriptions of the products and shall be free of defects in materials and workmanship. Any failure of the products to conform to this warranty will be remedied by Q.E.D. in the manner provided herein.

This warranty shall be limited to the duration and the conditions set forth below. All warranty durations are calculated from the original date of purchase.

1. Dedicated-Use Systems Products- 10 year warranty on dedicated bladder pumps equipped with Q.E.D. inlet screens, and purge pumps used in periodic, non continuous groundwater sampling (up to 52 sampling events per year.) All other components, equipment and accessories are warranted for one year.

2. Portable-Use Systems- Pumps, Controllers and water level meters are warranted for one year. Hose reels and Caps are warranted for ninety (90) days. Tubing and Purge Mizers are covered by a ninety (90) day material and workmanship warranty. There will be no warranty for application on tubing and Purge Mizers when used as part of a Portable System.

3. Separately sold parts and Spare Parts Kits- Separately sold parts and spare parts kits are warranted for ninety (90) days. Repairs performed by Q.E.D. are warranted for ninety (90) days from date of repair or for the full term of the original warranty, whichever is longer.

Buyers' exclusive remedy for breach of said warranty shall be as follows:if, and only if, Q.E.D. is notified in writing within applicable warranty period of the existence of any such defect in the said products, and Q.E.D. upon examination of any such defects, shall find the same to be within the term of and covered by the warranty running from Q.E.D. to Buyer, Q.E.D. will, at its option, as soon as reasonably possible, replace or repair any such product, without charge to Buyer. If Q.E.D. for any reason, cannot repair a product covered hereby within four (4) weeks after receipt of the original Purchaser's/Buyer's notification of a warranty claim, then Q.E.D.'s sole responsibility shall be, at its option, either to replace the defective product with a comparable new unit at no charge to the Buyer, or to refund the full purchase price. In no event shall such allegedly defective products be returned to Q.E.D. without its consent, and Q.E.D.'s obligations of repair, replacement or refund are conditioned upon the Buyer's return of the defective product to Q.E.D.

**IN NO EVENT SHALL Q.E.D. ENVIRONMENTAL SYSTEMS, INC. BE LIABLE FOR CONSEQUENTIAL OR INCIDENTAL DAMAGES FOR BREACH OF SAID WARRANTY.**

The foregoing warranty does not apply to major sub-assemblies and other equipment, accessories and parts manufactured by others, and such other parts, accessories, and equipment are subject only to the warranties, if any, supplied by the respective manufacturers. Q.E.D. makes no warranty concerning products or accessories not manufactured by Q.E.D. In the event of failure of any such product accessory, Q.E.D. will give reasonable assistance to the Buyer in obtaining from the respective manufacturer whatever adjustment is reasonable in light of the manufacturer's own warranty.



**THE FOREGOING WARRANTY IS IN LIEU OF ALL OTHER WARRANTIES, EXPRESS-ED, IMPLIED OR STATUTORY (INCLUDING BUT NOT LIMITED TO THE WARRANTIES OF MERCHANTABILITY AND FITNESS FOR A PARTICULAR PURPOSE), WHICH OTHER WARRANTIES ARE EXPRESSLY EXCLUDED HEREBY,** and of any other obligations or liabilities on the part of Q.E.D., neither assumes nor authorizes any person to assume for it any other obligation or liability in connection with said products, materials and/or workmanship.

It is understood and agreed that Q.E.D. shall in no event be liable for incidental or consequential damages resulting from its breach of any of the terms of this agreement, nor for special damages, nor for improper selection of any product described or referred to for a particular application.

This warranty will be void in the event of unauthorized disassembly of component assemblies. Defects in any equipment that result from abuse, operation in any manner outside the recommended procedures, use and applications other than for intended use, or exposure to chemical or physical environment beyond the designated limits of materials and construction will also void this warranty. Q.E.D. shall be released from all obligations under all warranties if any product covered hereby is repaired or modified by persons other than Q.E.D.'s service personnel unless such repair by others is made with the written consent of Q.E.D.

If any product covered hereby is actually defective within the terms of this warranty, Purchaser must contact Q.E.D. for determination of warranty coverage. If the return of a component is determined to be necessary, Q.E.D. will authorize the return of the component, at owner's expense. If the product proves not to be defective within the terms of this warranty, then all costs and expenses in connection with the processing of the Purchaser's claim and all costs for repair, parts and labor as authorized by owner hereunder shall be borne by the purchaser.

#### RESPONSIBILITY OF THE PURCHASER

The original Purchaser's sole responsibility in the instance of a warranty claim shall be to notify Q.E.D. of the defect, malfunction, or other manner in which the terms of this warranty are believed to be violated. You may secure performance of obligations hereunder by contacting the Customer Service Department of Q.E.D. and:

1. Identifying the product involved (by model or serial number or other sufficient description that will allow Q.E.D. to determine which product is defective).
2. Specifying where, when, and from whom the product was purchased.
3. Describing the nature of the defect or malfunction covered by this warranty.
4. Sending the malfunctioning component, after authorization by Q.E.D. to:

QED Environmental Systems, Inc.  
6155 Jackson Rd.  
Ann Arbor, Michigan 48103

